

ENGINEERING STANDARD

FOR

PROCESS DESIGN OF LIQUID & GAS

TRANSFER AND STORAGE

ORIGINAL EDITION

DEC. 1997

This standard specification is reviewed and updated by the relevant technical committee on July 2006. The approved modifications are included in the present issue of IPS.

CONTENTS :	PAGE No.
0. INTRODUCTION	4
1. SCOPE	5
2. REFERENCES	5
3. DEFINITIONS AND TERMINOLOGY	7
4. SYMBOLS AND ABBREVIATIONS	8
5. UNITS	9
 SECTION A	 9
6. STORAGE AND HANDLING OF CRUDE OIL AND REFINERY PRODUCTS	9
6.1 General	9
6.2 Design Requirements	9
6.2.2 Wind load	9
6.2.3 Earthquake load	9
6.2.4 Rainfall intensity	10
6.3 Tank Dimensions, Capacities and Layout	10
6.3.1 General	10
6.3.2 Layout consideration	10
6.3.3 Spacing of tanks for petroleum stocks	11
6.3.4 Types of storage tanks	12
6.4 Shell Attachments and Tank Appurtenances	15
6.4.1 General	15
6.4.2 Shell fittings	15
6.5 Fixed Roof Fittings	16
6.5.1 Manhole	16
6.5.2 Vents and relief valves	16
6.5.3 Sample points on slops tankage	16
6.5.4 Control instrumentation for slops tankage	16
6.5.5 Water drains	16
6.6 Floating Roof Fittings	17
6.6.1 Manholes	17
6.6.2 Vents	17
6.6.3 Heaters	17
6.6.4 Drains	17
6.6.5 Arrangements for sampling and dipping	17
6.7 Safe Entry and Cleaning of Petroleum Storage Tank	17
6.8 Piping System	18
6.8.1 General	18
6.8.2 Piping layout	18
 SECTION B	 19
7. STORING AND HANDLING OF LIQUEFIED PETROLEUM GASES; LPG	19
7.1 General	19
7.2 Physical Properties and Characteristics	19

- 7.3 Requirements 19
 - 7.3.1 Siting 19
 - 7.3.2 Layout and spacing 20
 - 7.3.3 Type and size of storage vessels 20
 - 7.3.4 Spill containment 20
- 7.4 Design Considerations 21
 - 7.4.1 Storage vessels 21
 - 7.4.2 Refrigeration system 24
 - 7.4.3 Pumps 25
 - 7.4.4 Fire protection facilities 26
 - 7.4.5 Piping 26
 - 7.4.6 Vaporizers 26
 - 7.4.7 Instrumentation 27
- 7.5 Transfer of LPG Within the Off-Site Facilities of OGP Plants 27
 - 7.5.1 General 27
 - 7.5.2 Requirements 27

- SECTION C 28

- 8. LIQUEFIED NATURAL GAS (LNG); STORAGE AND TRANSFER FACILITIES 28
 - 8.1 Introduction 28
 - 8.2 General Considerations 28
 - 8.2.1 Physical properties 28
 - 8.2.2 Spacing and diking 28
 - 8.3 Criteria and Requirements 28
 - 8.3.1 Cryogenic process system 28
 - 8.4 Transfer of LNG and Refrigerants 31
 - 8.4.1 General requirements 31
 - 8.4.2 Piping system 32
 - 8.5 Fire Protection 32

- SECTION D 33

- 9. STORAGE AND HANDLING OF ETHANE AND ETHYLENE 33
 - 9.1 General 33
 - 9.1.1 Scope 33
 - 9.1.2 Reference publications 33
 - 9.3 Distance Requirements and Exposure Limitations 33
 - 9.3.1 General 33
 - 9.3.2 Minimum distance requirement and layout 33
 - 9.3.3 Exposure and other limitations 34
 - 9.3.4 Dike and drainage provisions 34
 - 9.4 Tank Accessories 34
 - 9.4.1 General 34
 - 9.4.2 Liquid level indicator 34
 - 9.4.3 Level alarm 34
 - 9.4.4 Pressure gage 34

9.4.5 Pressure and vacuum relieving devices	34
9.5 Piping Requirements	35
9.6 Transfer, Loading and Unloading Facilities	35
9.6.1 Sizing	35
9.6.2 Design	35
9.6.3 Equipment	36
9.7 Refrigeration System	36
9.7.1 Refrigeration load	36
9.7.2 Other requirements	36
 SECTION E	 37
 10. STORING AND HANDLING OF ETHANOL AND GASOLINE - ETHANOL BLENDS	 37
10.1 General.....	37
10.2 Scope	37
10.3 Material Selection.....	37
10.4 Requirements	38
10.4.1 Tanks and tank lining	38
10.4.2 Handling	38
10.4.3 Piping	38
10.5 Safety and Fire Protection	38
 SECTION F	 39
 11. STORING AND HANDLING OF GASOLINE - METHANOL/COSOLVENT BLENDS	 39
11.1 General.....	39
11.2 Material Selection.....	39
11.3 Requirements	39
TABLE 5 - COMPATIBILITY OF COMMONLY USED MATERIALS	40
METALS	40
ELASTOMERS	40
POLYMERS.....	40
 APPENDICES:	
 APPENDIX A TABLE A.1 - NOMINAL CAPACITIES OF STANDARD VERTICAL CYLINDRICAL TANKS	 41
APPENDIX B TYPICAL LAYOUT LPG PRESSURE STORAGE WITH COLLECTION PIT/RETAINING SYSTEM	42
APPENDIX C ARRANGEMENT OF DRAIN FACILITIES.....	43
APPENDIX D AIR - DRYER INSTALLATION FOR ETHANOL STORAGE TANKS AT TERMINALS.....	44
APPENDIX E REFINERIES LIQUEFIED PETROLEUM GAS SPECICATION	45

0. INTRODUCTION

"Process Design of Offsite Facilities for OGP Industries" is broad and contains various subjects of paramount importance. Therefore, a group of Process Engineering Standards are prepared to cover this subject. This group includes the following Standards:

<u>STANDARD CODE</u>	<u>STANDARD TITLE</u>
IPS-E-PR-360	"Process Design of Liquid and Gas Transfer and Storage"
IPS-E-PR-370	"Process Design of Loading & Unloading Facilities"
IPS-E-PR-380	"Process Design of Solids Handling System"

This Engineering Standard Specification covers:

"PROCESS DESIGN OF LIQUID AND GAS TRANSFER AND STORAGE"

1. SCOPE

This Standard Specification is intended to cover the minimum requirements and criteria to be considered in process design of liquid and gas transfer and storage facilities in OGP Industries.

The requirements outlined in this Standard Specification deal with individual items of equipment and other facilities such as storage tanks and accessories, pumps/compressors and piping connection, instrumentation, fire protection and safety instruction, layout and spacing and other aspects, but all to the extent of process design consideration limits.

1.1 This Standard Specification covers the following sections:

Section A:	Storage and Handling of Crude Oil and Refinery Products.
Section B:	Storage and Handling of Liquefied Petroleum Gases; 'LPG'.
Section C:	Liquefied Natural Gas 'LNG' or 'NGL' Storage and Transfer Facilities.
Section D:	Storage and Handling of Ethane and Ethylene.
Section E:	Storing and Handling of Ethanol and Gasoline-Ethanol Blends.
Section F:	Storing and Handling of Gasoline-Methanol/Cosolvent Blends.

Note:

This standard specification is reviewed and updated by the relevant technical committee on July 2006. The approved modifications by T.C. were sent to IPS users as amendment No. 1 by circular No. 287 on July 2006. These modifications are included in the present issue of IPS.

2. REFERENCES

Throughout this Standard the following dated and undated standards/codes are referred to. These referenced documents shall, to the extent specified herein, form a part of this standard. For dated references, the edition cited applies. The applicability of changes in dated references that occur after the cited date shall be mutually agreed upon by the Company and the Vendor. For undated references, the latest edition of the referenced documents (including any supplements and amendments) applies.

API (AMERICAN PETROLEUM INSTITUTE)

API Recommended Practice 520, Parts: I & II, 7 th Ed., 2000	"Sizing, Selection, and Installation of Pressure-Relieving Devices in Refineries"
API RP 521 4 th Ed., 1997	"Guide for Pressure-Relieving and Depressuring Systems"
API Standard 610 9 th Ed., 2003	"Centrifugal Pumps for Petroleum, Petrochemical and Natural Gas Industries"
API Standard 620 10 th Ed., 2002	"Design and Construction of Large, Welded, Low Pressure Storage Tanks"
API Standard 650 10 th Ed., 1998	"Welded Steel Tanks for Oil Storage"
API Standard 2000 5 th Ed., 1998	"Venting Atmospheric and Low-Pressure Storage Tanks: Nonrefrigerated and Refrigerated"

API Standard 2015 6 th Ed., 2001	"Requirements for Safe Entry and Cleaning of Petroleum Storage Tanks"
API Standard 2508 2 th Ed., 1985	"Design and Construction of Ethane and Ethylene Installations at Marine and Pipeline Terminals, Natural Gas Processing Plants, Refineries, Petrochemicals Plants, and Tank Farms"
API Standard 2510 8 th Ed., 2001	"Design and Construction of LPG Installations"
API Recommended Practice 1626 1 st Ed. 1985	"Storing and Handling of Ethanol and Gasoline-ethanol Blends at Distribution Terminals and Service Stations"
API Recommended Practice 1627 1 st Ed. 1986	"Storage and Handling of Gasoline-methanol/Cosolvent Blends at Distribution Terminals and Service Stations"
API Recommended Practice 2003 6 th Ed. 1998	"Protection Against Ignitions Arising Out of Static, Lightning and Stray Currents"
API Publication 2510A 2 nd Ed., 1996	"Fire-Protection Considerations for the Design and Operation of Liquefied Petroleum Gas (LPG) Storage Facilities"
API Publication 2015B 1 st Ed., 1981	"Cleaning Open-Top and Covered Floating Roof Tanks"

BSI (BRITISH STANDARDS INSTITUTION)

BS 470 1984	"Specification for Inspection, Access and Entry Openings for Pressure Vessels"
BS 2654:Part 3 1989	"Manufacturer of Vertical Steel Welded Non-Refrigerated Storage Tanks with Butt-welded Shells for Petroleum Industry"
BS 5429 Ed., 1988	"Code of Practice for Safe Operation of Small Scale Storage Facilities for Cryogenic Liquids"

ASME (AMERICAN SOCIETY OF MECHANICAL ENGINEERS)

ASME B31.3 Ed. 1987	"Process Piping"
ASME B31.4 Ed. 1994	"LPG, Anhydrous Ammonia, Pipeline Transportation Systems for Liquid hydrocarbons and other Liquids and Alcohol"
ASME Codes, Section VIII Divisions 1 and 2	"Boiler and Pressure Vessels Codes"

NFPA (NATIONAL FIRE PROTECTION ASSOCIATION)

NFPA 30 Ed. 2000	"Flammable and Combustible Liquid Code"
NFPA Standard 59A, Ed. 2001	"Standard for Production, Storage and Handling of LNG"
NFPA Vol. 2, 58 Ed., 2001	"Liquefied Petroleum Gas (LPG) Code"

UBC (UNIFORM BUILDING CODE)

IP (INSTITUTE OF PETROLEUM, LONDON)

IP 10 (A) July 1985	"Petroleum Measurement Manual", Part 10 : "Meter Proving" "
------------------------	--

ISO (INTERNATIONAL ORGANIZATION FOR STANDARDIZATION)

ISO 91-2, 1st. Ed., 1991	"Petroleum Measurement Table"
ISO 4266 Ed. 1994	"Direct Measurement of Level and Temperature in Storage Tank by Automatic Methods"

IPS (IRANIAN PETROLEUM STANDARDS)

IPS-E-CE-500	"Loads"
IPS-E-GN-100	"Units"
IPS-G-ME-100	"Atmospheric Above Ground Welded Steel Storage Tanks"
IPS-E-ME-110	"Large Welded Low Pressure Storage Tanks"
IPS-E-ME-120	"Aviation Turbine Fuel Storage Tanks"
IPS-M-ME-110	"Large Welded Low Pressure Storage Tanks"
IPS-M-ME-120	"Aviation Turbine Fuel Storage Tanks"
IPS-E-PI-240	"Plant Piping Systems"
IPS-E-PM-100	"General Design Requirements of Machineries"
IPS-E-PR-190	"Layout and Spacing"
IPS-E-PR-450	"Process Design of Pressure Relieving Systems Inclusive Safety Relief Valves"
IPS-E-PR-750	"Process Design of Compressors"
IPS-E-SF-200	"Fire Fighting Sprinkler Systems"

3. DEFINITIONS AND TERMINOLOGY

3.1 Design Pressure

The pressure used in design of equipment, a vessel or tank for the purpose of determining the

minimum permissible thickness or physical characteristics of its different parts. When applicable static head shall be included in the design pressure to determine the thickness of any specific part.

3.2 Dike

A structure used to establish an impounding area.

3.3 Liquefied Natural Gas (LNG)

A fluid in the liquid state composed predominantly of methane and which may contain minor quantities of ethane, propane, nitrogen, or other components normally found in natural gas.

3.4 Liquefied Petroleum Gas (LPG or LP-Gas)

Any material in liquid form that is composed predominantly of any of the following hydrocarbons or of a mixture thereof: propane, propylene, butanes (normal butane or isobutene), and butylenes.

3.5 Natural Gas Liquid (NGL)

A mixture of liquefied hydrocarbons extracted from natural gas by various methods to obtain a liquid product.

3.6 Standard Condition

A temperature of 15°C and a pressure of one atmosphere (101.325 kPa), which also is known as Standard Temperature and Pressure (STP).

3.7 Vaporizer

A device other than a container which receives LP-Gas in liquid form and adds sufficient heat to convert the liquid to a gaseous state.

3.7.1 Direct Vaporizer

A vaporizer in which heat furnished by a flame is directly applied to some form of heat exchange surface in contact with the liquid LP-Gas to be vaporized.

3.7.2 Indirect Vaporizer

A vaporizer in which heat furnished by steam, hot water, the ground, surrounding air or other heating medium is applied to a vaporizing chamber or to tubing, pipe coils, or other heat exchange surface containing the liquid LP-Gas to be vaporized; the heating of the medium used being at a point remote from the vaporizer.

4. SYMBOLS AND ABBREVIATIONS

GPA	Gas Processors Association
LPG	Liquefied Petroleum Gas
NGL	Natural Gas Liquid
NPSH	Net Positive Suction Head
OCMA	Oil Companies, Material Association
OGP	Oil, Gas and Petrochemical
RVP	Reid Vapor Pressure
STP	Standard Temperature and Pressure

5. UNITS

This Standard is based on International System of Units (SI), as per [IPS-E-GN-100](#) except where otherwise specified.

SECTION A

6. STORAGE AND HANDLING OF CRUDE OIL AND REFINERY PRODUCTS

6.1 General

6.1.1 The requirements of this Section apply to the storage of crude oil and refinery products in vertical cylindrical tanks and to storage tanks constructed of carbon steel, carbon manganese steel, tanks constructed of carbon and alloy steels or tanks constructed of non-ferrous materials.

6.1.2 Crude oil and the refinery products should normally be stored as follows:-

- a)** Lighter refinery products with $RVP \geq 79.3$ kPa (abs) is preferably to be stored in pressure vessels (e.g. spheres). However, where RVP of the lighter refinery products is exceeding local atmospheric pressure, the type of storage shall be pressure vessel.
- b)** Aviation fuels shall be stored in a covered floating roof inside a fixed roof tank.
- c)** Crude oil, naphtha and kerosene and other hydrocarbons with closed flash points at or below 45°C , [except the cases covered in (a) and (b) above] should be stored in tanks fitted with floating roofs.
- d)** Gas oils, diesel oils, lubricating oils, fuel oils and residues (with closed flash points above 45°C) should be stored in tanks fitted with non-pressure fixed roof.
- e)** Exceptions to the above may occur, as for example with the storage of feed stock for catalytic Units where, to prevent oxidation and ingress of moisture, the feed stock may be stored in a fixed roof vertical cylindrical low pressure (21 mbar and/or 2.1 kPa) tank under a gas blanket. Alternatively, a covered floating roof may be used in a fixed roof tank and in this case a non-pressure tank may be used.
- f)** Exceptions may also occur where adverse climatic conditions such as heavy snowfalls, preclude the use of floating roof type tanks. Fixed roof low pressure tanks (21 mbar and/or 2.1 kPa approximately), should be used in such cases.
- g)** For further requirement on the types of storage tanks see Clause 6.3.4.

6.2 Design Requirements

6.2.1 For engineering mechanical design the requirements of IPS Standard Specifications [IPS-G-ME-100](#), [IPS-E-ME-110](#), [IPS-E-ME-120](#) and for material selection [IPS-M-ME-110](#), and [IPS-M-ME-120](#) should be considered.

6.2.2 Wind load

6.2.2.1 The design wind velocity shall be according to the requirements stipulated in [IPS-E-CE-500](#).

6.2.3 Earthquake load

6.2.3.1 Earthquake load shall be specified in the job specification according to the latest edition of

Uniform Building Code (UBC).

6.2.3.2 The sloshing effect due to product movement in the tank as a result of earthquake movement shall be taken into account and calculations shall be submitted for the Company's approval to ensure soundness of design.

6.2.4 Rainfall intensity

6.2.4.1 Rainfall intensity should be specified as per site condition and the tank shall be designed accordingly except floating roof tanks. For this type of roof with the deck at its low position at operating level with drain valve(s) closed and, assuming no pontoon compartment is punctured, the deck support legs shall be designed to support the greater of the following loads:

- a) Rainfall of 115 mm of water uniformly distributed all over the deck.
- b) A live load as per project specification.

6.2.5 The snow load as specified in site conditions and incorporated in Paragraph 6.2.4.1.

6.2.6 When calculating for vacuum conditions during lowering of tank product in fixed roof tanks, maximum gravity transfer conditions should also be considered.

6.3 Tank Dimensions, Capacities and Layout

6.3.1 General

6.3.1.1 Tanks should conform to the standard diameters listed in Table A.1 in Appendix A. In selecting tank dimensions the highest tank compatible with permissible ground loading and economic aspect should normally be chosen.

6.3.1.2 Working capacity

6.3.1.2.1 An approximation of the working capacity of tanks may be achieved by assuming a negative capacity at the top of the tank of 500 mm height for floating roofs, and an ullage space in fixed roofs of 150 mm. For fixed roof tanks the dead space at the bottom will extend to 150 mm above the suction branch. For floating roof tanks the lowest position of the roof may be assumed to be 300 mm above the suction branch. If, exceptionally, landing of the roof is permitted by the Company during normal operation, the lowest position will be 150 mm above the suction branch.

6.3.1.2.2 The working capacity of each heated tank should be based on a minimum dip of 1 m above the steam coil.

6.3.1.2.3 The actual allowances will depend on such factors as the position and size of outlet branches, the position and type of pump, rate of pumping and type of level instrumentation.

6.3.2 Layout consideration

This Section covers the atmospheric storage and handling in refineries of crude petroleum and its products, with the exception of bitumen handling and storage, LPG pressure and refrigerated storage. The recommendations on tankage layout contained herein will normally apply to storage in tanks outside block limits of refinery process Units. Crude oil terminals associated with production are also covered by these recommendations.

The layout of tanks, as distinct from their spacing, shall take into consideration the accessibility needed for fire-fighting and the potential value of a storage tank farm in providing a buffer area between process plant and public roads, houses, etc. for environmental reasons.

The location of tankage relative to process Units must be such as to ensure maximum safety from possible incidents.

Primary requirements for the layout of refinery tank farms are summarized as follows:

- 1) Inter-tank spacings and separation distances between tank and boundary line and tank and other facilities are of fundamental importance (see Table 1).
- 2) Access roadways should be provided for approach to tank sites by mobile fire-fighting equipment and personnel.
- 3) The fire-water system should be laid out to provide adequate fire protection to all parts of the storage area and the transfer facilities.
- 4) Bunding and draining of the area surrounding the tanks should be such that a spillage from any tank can be controlled to minimize subsequent damage to the tank and its contents. They should also minimize the possibility of other tanks being involved.
- 5) Tank farms should preferably not be located of higher levels than process Units in the same catchment area.
- 6) Storage tanks holding flammable liquids should be installed in such a way that any spill will not flow towards a process area or any other source of ignition.

6.3.3 Spacing of tanks for petroleum stocks

Table 1 gives guidance on the minimum tank spacing for petroleum stocks. The following points should be noted:

- 1) Tanks of diameter up to 10 m are classed as Small Tanks.
- 2) Small Tanks may be sited together in groups, no group having an aggregate capacity of more than 8000 m³. Such a group may be regarded as one tank.
- 3) Where future changes of service of a storage tank are anticipated the layout and spacing should be designed for the most stringent case.
- 4) For reasons of fire-fighting access there shall not be more than two rows of tanks between adjacent access roads.
- 5) Fixed roof tanks with internal floating covers (see 6.3.4.3) should be treated for spacing purposes as fixed roof tanks.
- 6) Where fixed roof and floating roof tanks are adjacent, spacing should be on the basis of the tank(s) with the most stringent conditions.
- 7) Where tanks are erected on compressible soils the distance between adjacent tanks should be sufficient to avoid excessive distortion. This can be caused by additional settlements of the ground where the stressed soil zone of one tank overlaps that of the adjacent tank.
- 8) For unclassified petroleum stocks, spacing of tanks is governed only by constructional and operational convenience.

Figs. 1 to 4 show several typical tank installations, illustrating how the spacing guides are interpreted.

TABLE 1 - SPACING OF TANKS FOR PETROLEUM STOCKS

	FACTOR	TYPE OF TANK ROOF	RECOMMENDED MINIMUM DISTANCE
1	Within a group of Small Tanks.	Fixed or floating	Determined solely by construction/maintenance/operational convenience.
2	Between a group of Small Tanks and another group of Small Tanks or other larger tanks.	Fixed or floating	10 m minimum, otherwise determined by the size of the larger tanks (see 3 below).
3	Between adjacent individual tanks (other than Small Tanks).	a) Fixed	Half the diameter of the larger tank, but not less than 10 m and need not be more than 15 m.
		b) Floating	0.3 times the diameter of the larger tank, but not less than 10 m and need not be more than 15 m*.
4	Between a tank and the top of the inside of the wall of its compound.	Fixed or floating	Distance equal to not less than half the height of the tank. (Access around the tank at compound grade level must be maintained.)
5	Between any tank in a group of tanks and the inside top of the adjacent compound wall.	Fixed or floating	Not less than 15 m.
6	Between a tank and a public boundary fence.	Fixed or floating	Not less than 30 m.
7	Between the top of the inside of the wall of a tank compound and a public boundary fence or any fixed ignition source.	---	Not less than 15 m.
8	Between a tank and the battery limit of a process plant.	Fixed or floating	Not less than 30 m.
9	Between the top of the inside of the wall of a tank compound and the battery limit of a process plant.	---	Not less than 15 m.

*** In the case of crude oil tankage this 15 m option does not apply.**

6.3.4 Types of storage tanks

Tanks must be built to design criteria that ensure physical integrity of the tank against all reasonably expected forces such as tank contents, ground settlement or movement, wind and snow. Suitable codes relating to the design and construction of tanks and their associated fittings are BS 2654 and API Standard 650.

The main types of storage are as follows:

6.3.4.1 Floating roof tanks

Such tanks are generally used for liquids to minimize product loss and for safety and environmental reasons. There is a preference for floating roof over fixed roof tanks as the size of the tank increases, as the vapor pressure of the stored liquid increases, and when the flash point is below the storage temperature.

The roof consists of an arrangement of buoyancy compartments (pontoons) and floats on the liquid. It is sealed against the walls of the tank by mechanical means or by tubular type seals. The roof is provided with support legs which can be adjusted to hold it in either of two positions. The upper position should be high enough to permit access for tank cleaning and maintenance. The lower position should keep the roof just above inlet and outlet nozzles, the drainage system, and other accessories located near the tank bottom.

Floating roof tanks are normally equipped with rolling ladders. The tank shell is earthed and the roof and all fittings, such as the rolling ladder, are adequately bonded to the shell as a protection against

lightning. All internals such as gage floats, cables and mixers must also be suitably earthed to prevent accumulation of electric charge.

6.3.4.2 Fixed roof tanks

Such tanks are generally used in refineries where the product stored does not readily vaporize at the ambient or stored temperature conditions. The size of tank and flash point of the product stored will also influence the choice of tank as noted in 6.3.4.1. These tanks are operated with a vapor space above the liquid.

Depending on the materials to be stored, fixed roof tanks can be designed for storage at atmospheric pressure in which case they are equipped with open vents. For materials, they can be designed for pressures up to a maximum of about 50 mbar (5 kPa). Weak shell-to-roof welds can be incorporated to give protection to the tank shell in the event of excessive internal pressure. They are also designed for slight vacuum conditions not normally exceeding 6 mbar (0.6 kPa). Fixed roof tanks should be adequately earthed as a protection against lightning.

6.3.4.3 Fixed roof tanks with internal floating covers

Such tanks can be used, for example, where:

- a) snow loading on a floating roof may be a problem;
- b) contamination by rainwater of the liquid stored in a floating roof tank is unacceptable;
- c) there is an environmental or vapor loss problem with fixed roof tanks; or,
- d) contact of the stored liquid with air should be avoided.

Pressure/vacuum valves or ventilating slits may be used. In the latter case vent outlets are required in the upper ring of the tank shell and in the highest point of the fixed roof. This will assist in reducing the gas concentration in the space between the fixed roof and the internal floating cover to below the lower flammability limit. Such vent outlets should be constructed so as to prevent the ingress of snow and rain. When screens are provided, the mesh opening should not be less than 6 mm square.

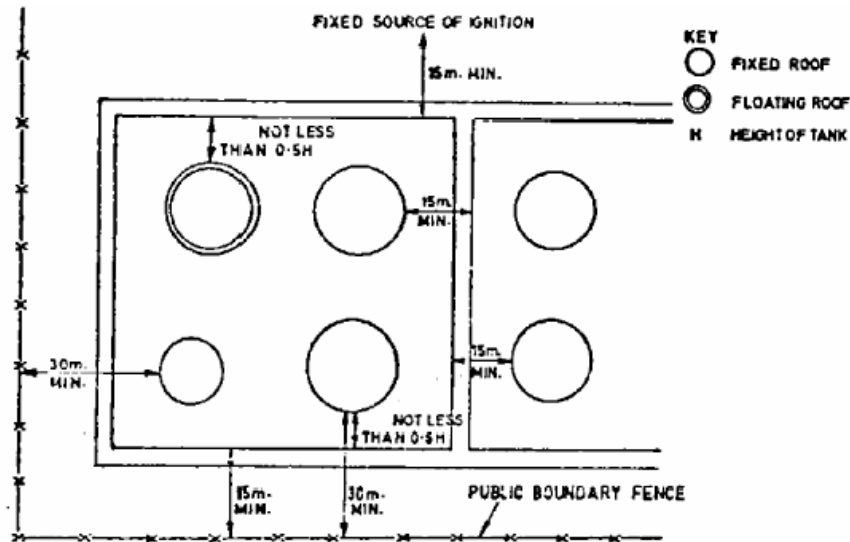

TANK AND COMPOUND WALL DISTANCES FROM TYPICAL FEATURES

Fig. 1

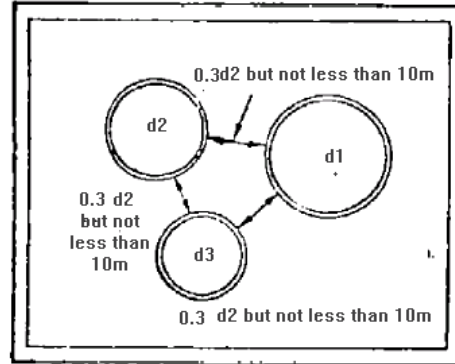
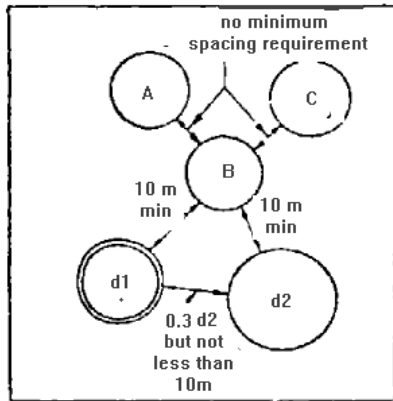

Tanks A, B, C are fixed or floating roof small tanks (less than 10 m diameter) with a total capacity of less than 8000 m³, no inter-tank spacing requirements other than for construction/operation/maintenance convenience.
 Tank D1 and D2 are tanks with diameter greater than 10 m and with diameter of D2 greater than D1.

Floating roof tanks of diameter D1 D2 D3 greater than 10 m within the same compound. D1 greater than D2 and D2 greater than D3.

INTER-TANK SPACINGS BETWEEN SMALL AND LARGER TANKS
 Fig. 2

INTER-TANK SPACINGS FOR FLOATING ROOF TANKS (GREATER THAN 10 m DIAMETER)
 Fig. 3

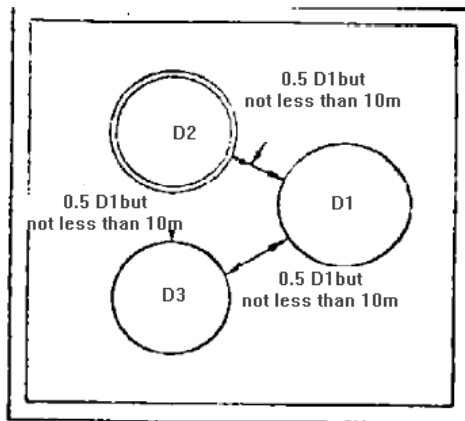

Fixed and floating roof tanks within the same compound, D1 greater than D2, D2 equal to D3.

INTER-TANK SPACINGS FOR FIXED AND FLOATING ROOF TANKS (GREATER THAN 10 m DIAMETER)

Fig. 4

Key:

- Fixed Roof
- Floating Roof

There has been some history of internal floating covers sinking in service; they should therefore be carefully designed to minimize such a possibility. The internal floating cover should also be designed to avoid fouling or obstruction of tank connections and of the fixed roof members and should be electrically bonded to the main tank structure. The tank should be adequately earthed as a protection against lightning. For further design details refer to API Bulletin 2519 and BS 2654.

6.4 Shell Attachments and Tank Appurtenances

For shell and roof design, reference is made to [IPS-G-ME-100](#) and [IPS-E-ME-110](#).

6.4.1 General

6.4.1.1 Shell attachments shall be designed in conformance with API Standard 650 and the followings:

- a) The orientation of the roof and shell fittings should permit the installed equipment to work accurately and effectively. For example, the flow from a mixer should not be hindered unduly by the siting of heaters.
- b) The recommendations of ISO 4266 should be considered for automatic liquid level and temperature measuring instruments on the storage tank.

6.4.2 Shell fittings

6.4.2.1 The checklist below covers tank shell fittings which may be required, but the number, type, and size and location of fittings should be specified in design stage for each tank to the tank fabricator.

6.4.2.1.1 Branches for tank contents such as:

Inlet, Outlet, Gas Blanket, Pumpout, Water Draw-Off, Jetting and Mixers.

6.4.2.1.2 Branch connections for services and maintenance such as:

Steam, Condensate, Foam (for Fire Fighting), Flush Type Clean Out Doors, Non-Flush Clean Out Doors.

Note:

The last two, items are not normally fitted, but when they are required, the limitations imposed by BS 2654 on shell design must be observed.

6.4.2.1.3 Branch for instruments such as:

Level Alarms, (high and low positions), Mixer Cut-Out, Float Switches, Thermowells as required.

Note:

For fuel oil and slop tanks, thermowells should be located approximately 750 mm above the heating element. For other tanks, the position should be agreed with the Company.

6.4.2.1.4 Other shell fittings such as:

Fire Fighting Water Spray, Manholes and Earthing Luges which shall be as API Standard 650.

6.5 Fixed Roof Fittings

6.5.1 Manhole

6.5.1.1 One roof manhole of diameter 600 mm, should be provided for tanks 20 m diameter or less and two for tanks over 20 m diameter.

6.5.2 Vents and relief valves

6.5.2.1 The number and size of vents provided shall be based on the venting capacity obtained from the API Standard 2000 and should be sufficient to prevent any accumulation of pressure or vacuum (including that arising from inert gas blanketing) exceeding the design conditions specified for and approved by the Company.

6.5.2.2 For fixed roof low pressure tanks (20 mbar and/or 2 kPa) containing low flash point material a pressure and vacuum type breather valve should be designed and provided upon the approval of the Company. These valves should be fitted with a screen of appropriate mesh.

6.5.2.3 Pressure and vacuum relieving devices shall be designed in accordance with provisions of API Standard 620 and requirements of 6.5.2.2 above.

6.5.2.4 For fixed roof non-pressure tanks containing high flash point material, which is never heated above the flash point, free vents of the Company approved design should be provided. These free vents should be fitted with screens of appropriate mesh. If however the contents of a fixed roof tank are liable to be heated above the flash point then pressure and vacuum valves should be fitted.

6.5.3 Sample points on slops tankage

6.5.3.1 On tanks where liquid interfaces have to be determined, sample points operable from ground level should be considered in design at appropriate vertical intervals. The points should be discharged to a common oily drain; and where necessary, the system shall be heat traced to prevent plugging.

6.5.4 Control instrumentation for slops tankage

6.5.4.1 Temperature

6.5.4.1.1 For heated tanks a multipoint high temperature (remote) alarm is required, with 6 sensing points at suitable vertical intervals, the lowest being 750 mm above the steam coil. The alarm is to operate in a permanently manned control room.

On the opposite side of the tank, a temperature sensing element is required 750 mm above the steam coil, linked with the steam supply control and shut off valve. A separate thermowell with local temperature indicator is also required at this point.

6.5.4.1.2 In the case of ballast tanks, as the steam coils are used only occasionally to aid sludge removal, and for all unheated tanks, one local temperature indicator is sufficient.

6.5.4.2 Level

6.5.4.2.1 A local level indicator should be provided, and where the type of installation demands, remote indication should in addition be considered. A high level (remote) alarm should operate in a permanently manned control room.

6.5.5 Water drains

Floating roof tanks should be equipped with means for draining rainwater from the upper surface of the roof. For pontoon-type roofs with internal articulated pipe drains a non-return valve should be provided near the roof end to prevent backflow of stored product on to the roof in case of a leakage in the jointed pipe.

For double-deck type roofs this non-return valve is not necessary owing to the extra height of the double roof, but an emergency roof drain should be fitted.

As an alternative to articulated pipes for draining water from tank roofs, internal flexible hoses are also used. It is essential to ensure that the hoses cannot be trapped between the roof support legs and the tank bottom.

All tanks should be fitted with a water draw-off sump and drain line leading to a valved outlet on the tank shell, for removal of water accumulation inside the tank.

6.6 Floating Roof Fittings

6.6.1 Manholes

Manholes should be provided to permit entry to tanks, and to facilitate gas-freeing and tank cleaning operations. Such manholes should be large enough to permit entry when full protective clothing is worn. Reference should be made to BS 470 and API Standard 650. At least one manhole should be provided in the lowest shell strake and one in the roof of a vertical tank. For tanks with diameters greater than 25 m consideration should be given to providing a minimum of two manholes in the lowest shell strake and two in the roof to facilitate tank ventilation for cleaning purposes.

6.6.1.1 600 mm diameter deck manholes should be provided for pontoon roofs, and 600 mm diameter through manholes for double deck roofs.

6.6.1.2 One manhole should be fitted to roofs up to 20 m diameter and two for larger roofs.

6.6.1.3 One 500 mm diameter manhole should be provided for each pontoon compartment, unless otherwise specified.

6.6.2 Vents

6.6.2.1 Automatic bleeder vents shall be used on all floating roof tanks. Size will be specified on data sheet. Automatic bleeder vents should be made of stainless steel.

6.6.2.2 Vendor shall submit descriptive literature on the pressure vacuum vent valves, swing lines with appurtenances and floating roof rim seals with his questions. Integral vacuum breakers and pressure relief valves may be offered as an acceptable design.

6.6.2.3 The number of rim vents to be fitted to the roof is to be specified by the Vendor.

6.6.2.4 The Vendor should be informed of the maximum flow rates into and out of the tank to allow him to determine the size and number of bleeder vents required.

6.6.3 Heaters

6.6.3.1 Tank heaters shall be exclusively of removable tube bundle type (whether finned or not) and shall be approved by the Company. For bitumen storages only removable bear tube bundle shall be used.

6.6.4 Drains

Emergency open type drains may be fitted if recommended by the Vendor/fabricator to double deck type roofs or to pontoon roofs having more than 50% pontoon area. A drain plug should be provided for use when taken out of service.

6.6.5 Arrangements for sampling and dipping

A tube DN 150 (6 inch) should be located at the gaging platform, for the combined purposes of leg guide and dipping. A separate sample hatch DN 200 (8 inch) is required with appropriate drawing approved by the Company, located under the gaging platform.

6.7 Safe Entry and Cleaning of Petroleum Storage Tank

6.7.1 All of the provisions regarding to safe entry and cleaning requirements given in API publication 2015 shall be considered in design of petroleum storage tanks. Provisions for cleaning of open-top

and covered floating roof tanks as given in API publication 2015 B shall be considered for these specific tanks.

6.8 Piping System

6.8.1 General

Piping system shall be designed in accordance with [IPS-E-PI-240](#), "Plant Piping Systems" and the following requirements:

6.8.1.1 Piping carrying crude oil and petroleum products should meet the requirements of ASME Codes for process piping B31.3. For the piping located inside refinery/plant and ASME B31.4 for the transportation pipelines outside refinery/plant.

6.8.1.2 Facilities should be provided on all pipelines to enable the lines to be pigged before commissioning.

6.8.1.3 Thermal relief valves should be provided on each section of liquid filled pipeline, that could be isolated between block valves.

6.8.1.4 Vent and drain connections should be provided where necessary for satisfactory commissioning and operation.

6.8.1.5 Pipes and fittings supplied integrally with vessels, pumps and other equipment, may be to supplier's standards when agreed with the Company.

6.8.1.6 Pipe sizes smaller than DN 15 (½ inch) should not normally be used except for instruments. The use of steel pipe in DN 32 (1¼ inch), DN 65 (2½ inch), DN 90 (3½ inch), DN 125 (5 inch), DN 175 (7 inch), DN 225 (9 inch) sizes should be avoided.

6.8.2 Piping layout

6.8.2.1 Provision should be made where necessary in piping system to prevent freezing or to prevent difficulties resulting from high velocities, by following typical methods:

- a) Heating may be external or internal tracing, jacketing or grouping with adjacent hot oil lines.
- b) Insulation.
- c) Grading or sloping to permit complete draining.
- d) Burying below frost line.

6.8.2.2 Where process lines need to be drained completely, the piping should be sloped and should be provided with drainage points e.g.:

- a) In multipurpose-lines;
- b) Where hazardous or valuable liquids may be split during dismantling of pipe work;
- c) Where there may be polymerization or settling of solids from liquids in the piping;
- d) Where there may be contamination of pure products due to liquids standing in lines subject to intermittent use.

6.8.2.3 Isolating valves/line blinds

Piping systems should contain a sufficient number of valves to enable each system to be operated safely and efficiently. Such valves should enable the system to be shut down quickly in an emergency, but without damage to equipment due to pressure surge. Where valves are not of the rising stem type, they should embody a clear indication of the valve position.

Adequate access stairways or ladders, and operating platforms, where necessary, should be provided to facilitate the manipulation of valves.

All nozzles, including drains on a tank shell should be provided with block valves adjacent to the tank shell or as close as practicable. Where soft seated valves are present, they should be of fire-safe quality.

Line blinds should be of a type which will indicate whether the line is blinded or open. A line blind design allowing swinging of the blind without the necessity to drain the pipeline contents may be considered.

SECTION B**7. STORING AND HANDLING OF LIQUEFIED PETROLEUM GASES; LPG****7.1 General**

7.1.1 The term liquefied petroleum gases (LPG or LP-Gas) as used in this Specification is to be taken as applying to any material which is composed predominantly of any of the following hydrocarbons or mixtures thereof: propane, propene, normal and isobutane, butenes.

7.2 Physical Properties and Characteristics

7.2.1 The composition of a specific grade of LPG product is not normally rigidly specified and thus, product composition can vary from one particular refinery or petrochemical process plant to another, hence, for process design requirement of LPG storage and handling facilities, the physical, thermodynamic and other properties of the product should be specified in project specification.

7.2.2 LPG specification based on NIORDC's different refineries product is product is presented in Appendix E. Noting that, whenever the words butane or propane appear hereafter, the commercial of these products are intended. Pure and commercial products will be differentiated from one another as necessary for design and installation of relevant storage and handling systems.

7.3 Requirements**7.3.1 Siting****7.3.1.1 General**

7.3.1.1.1 Site selection is concerned with minimizing the potential risk to adjacent property presented by the storage facility and the risk presented to the storage facility by a fire or explosion on adjacent property.

The following factors should be considered during site selection:

- a) Proximity to populated area;
- b) Proximity to public ways;
- c) Risk from adjacent facilities;
- d) Storage quantities;
- e) Present and predicted development of adjacent properties;
- f) Topography of the site, including elevation and slope;
- g) Access for emergency response;
- h) Utilities;
- i) Requirements for receipt and shipment of products;
- j) Local code and regulations;
- k) Prevailing wind conditions.

7.3.1.2 Above ground pressurized LPG tanks and equipment

7.3.1.2.1 Pressurized LPG tanks shall not be located within the building, within spill containment area of flammable or combustible liquid storage tanks as determined in NFPA 30, or within the spill contaminant area for refrigerated storage tanks.

7.3.1.2.2 Rotating equipment and pumps taking suction from the LPG tanks shall not be located within the spill contaminant area of any storage facility. Unless provisions are made to protect the storage vessel from potential fire exposure.

7.3.1.2.3 Horizontal vessels used to store LPG should be oriented so that their longitudinal axes do not point toward other containers, process equipment, control rooms, loading and unloading facilities, or flammable or combustible liquid storage facilities located in the vicinity of the horizontal vessel.

7.3.1.2.4 Horizontal vessels used to store LPG with the capacity of 50 m³ and more should be grouped with no more than six vessels in one group. Where multiple groups of horizontal LPG vessels are to be provided, each group should be separated from adjacent groups by minimum horizontal shell-to-shell distance of 15 m.

7.3.2 Layout and spacing

7.3.2.1 General

7.3.2.1.1 Spacing and design of LPG facilities are interdependent and must be considered together. Spacing requirement used shall be in accordance with [IPS-E-PR-190](#). However the requirements specified in 7.3.2.1.2 in the Clause 7.3.2 shall also be considered in addition and/or as an amendment to [IPS-E-PR-190](#) (see Note 1).

7.3.2.1.2 Spacing should be sufficient to minimize both the potential for small leak ignition and the exposure risk to adjacent vessels, equipment or installations should ignition occur.

Note 1:

A typical lay-outs are illustrated in Appendices A and B. These illustrate the slope of tank sites, the location of vessels with respect to each other, the positioning of separation wall, when necessary, and manifolds with respect to vessels.

7.3.2.2 Minimum distance requirement for above ground LPG tanks

The minimum horizontal distance between shell of a pressurized LPG tanks and the line of adjoining property that may be developed shall be as specifically given in API Standard 2510 under Clause 5.1.2.

7.3.3 Type and size of storage vessels

7.3.3.1 The type, size and number of vessels to be used must be based on operational requirements and technical/economical considerations. The following is given as guidance for the types normally used and the size limitations generally applicable to them.

- a)** Horizontal vessels which can in many instances shop fabricated, and move to site in one piece, are normally used for unit capacities up to 200 m³.
- b)** Vertical cylindrical vessels have an advantage to horizontal vessels in that they require less space for a specific capacity. They are normally limited in size to a maximum of 10 m diameter and 25 m height.
- c)** Spherical vessels (spheres) are normally considered if the unit capacity exceeds 400 m³.

7.3.4 Spill containment

7.3.4.1 Spill containment should be provided in locations in which any of the following conditions exist:

- a) The physical properties of the stored LPG (for example, a mixture of butane and pentane) make it likely that liquid material will collect on the ground.
- b) Climatic conditions during portions of the year make it likely that liquid material collect on the ground.
- c) The quantity of material that can be spilled is large enough that any unvaporized material will result in a significant hazard.

7.3.4.2 If spill containment is to be provided, it shall be remote impoundment of spilled material or by diking the area surrounding the vessel.

7.3.4.3 The pronounced volatility of LPG generally allows impoundment areas to be reduced and in some cases makes spill containment of LPG impractical. However, the ground and surrounding of a vessel used to store LPG shall be graded to drain any spills to a safe area away from the vessel.

7.3.4.4 All provisions under Clause 3.2 of API Standard 2510 regarding to establishment of spill containment facilities for LPG storage vessels shall be considered as an integral part of this Standard Specification in design and installation of LPG storage vessels.

7.4 Design Considerations

7.4.1 Storage vessels

7.4.1.1 Design code

7.4.1.1.1 Vessels design shall meet the requirements of Section VIII of the ASME Boiler and Pressure Vessel Code (commonly called the ASME Code), Division 1 or 2.

7.4.1.1.2 When complete rules and design requirement for any specific design are not given, the manufacturer, subject to the approval of the Company, shall provide a design as safe as would be provided in the currently applicable ASME Code given in 7.4.1.1.1 above.

7.4.1.2 Design pressure

7.4.1.2.1 It is assumed that, the maximum operating pressure at the top of a vessel is equivalent to the vapor pressure of the product being handled at the maximum temperature that the vessel's contents may reach under prolonged exposure of the vessel to solar radiation "the assessed temperature".

7.4.1.2.2 The design pressure to be used for the top of the vessel shall be equal to the greater of :

- a) 110% of the maximum operating pressure;
- b) the maximum operating pressure plus 170 kPa (1.7 kg/cm²).

7.4.1.2.3 The design pressure to be used for the bottom of the vessel shall be that of 7.4.1.2.2 above for the top of the vessel plus the static head of the content.

7.4.1.3 Design vacuum

7.4.1.3.1 LPG storage vessel design shall consider vacuum effects. Where an LPG vessel is not designed for full vacuum, some alternatives, in order of preference, are as follows:

- a) Design for partial vacuum with a vacuum relief valve and a connection to a reliable supply of inert gas. This alternative requires a means of venting inert gas that has been admitted to the storage vessel after it is no longer required for maintaining pressure.
- b) Design for partial vacuum with a vacuum relief valve and a connection to a reliable supply of hydrocarbon gas. This alternative may compromise product quality.
- c) Design for partial vacuum with a vacuum relief valve that admits air to the vessel. This alternative presents a hazard from air in the LPG storage vessel, and this hazard shall be considered in the design.

7.4.1.4 Design temperature

7.4.1.4.1 Both a minimum and a maximum design temperature should be specified. In determining a maximum design temperature, consideration should be given to factors such as ambient temperature, solar input, and product run down temperature. In determining a minimum design temperature, consideration should be given to the factors in the preceding sentence plus the auto refrigeration temperature of the stored product when it flashes to atmospheric pressure.

7.4.1.5 Filling and discharge line

7.4.1.5.1 Only one product line shall be connected to the bottom of the vessel and this line shall be used for filling, discharge and drainage. However operational considerations may dictate the use of a separate top connected filling line.

7.4.1.5.2 To enable complete drainage of the vessel, the connection of the bottom line to the vessel shall be made flush with the inside of the vessel. A typical arrangement of the drain connection to the bottom line is given in Appendix C.

7.4.1.5.3 Top connected filling and vapor lines shall be provided with a remote-controlled fail-safe type shut-off valve if the line extends below the maximum liquid level, otherwise a shut-off valve plus either a non-return valve or an excess flow valve may be used.

7.4.1.5.4 The product line connected to the bottom of the vessel shall be provided with either:

a) A remote-controlled fail-safe type shut-off valve located at the manifold side of the separation wall between manifold and vessel. This line is to have a minimum size of DN 100 and should be of Schedule 80 for DN 100 size and Schedule 40 for DN 150 and larger. A hand-operated fire-safe valve should be provided between the remote controlled valve and the manifold separation wall if it is considered necessary;

b) A remote-controlled failed-safe type valve mounted internally in the vessel. Design consideration should be given to the possibility/practicability of emptying the vessel in the case of malfunctioning of the remote controlled valve. If considered necessary a by-pass line connected to the vessel shall be provided with a shut-off valve and shall be blanked.

7.4.1.5.5 Piping connections between container and manifold shall be designed to provide adequate allowances for construction, expansion, vibration, and settlement. In this regard, NFPA requirements under Clause 4.3 shall be considered.

7.4.1.5.6 Other considerations for piping design should be taken as per requirements specified in API Publication 2510A paragraph 2.7.1 and API Standard 2510 section 8.

7.4.1.6 Water drawing

7.4.1.6.1 Water can accumulate under certain conditions in LPG storage vessels and must be removed for product quality reasons. Also, in Freezing climates, ice formation in bottom connections can rupture piping and lead to major LPG releases. Thus facilities shall be provided and procedures shall be established to handle water draw-off safely.

7.4.1.6.2 Considering the potential risk associated with improper handling of water removal, a detailed written procedure should be prepared and rigidly followed. The procedure outlined in API Publication 2510A under Paragraphs 3.4.4.1 through 3.4.4.3 is recommended to be considered during the entire process of water removal.

7.4.1.7 Safety/relief valves

7.4.1.7.1 LPG storage vessels shall be adequately protected by safety/relief valves directly connected to the vapor space of the vessel. Safety/relief valves shall be provided to protect against:

- a) overpressurization due to abnormal operational conditions, e.g., overfilling, high run-down temperatures or high temperature due to solar radiation;
- b) overpressurization due to fire exposure.

7.4.1.7.2 Consideration should be given to the provision of a spare safety/relief valve or connection such that to facilitate servicing/maintenance of safety/relief valves.

7.4.1.7.3 The materials used for safety/relief valves including components, e.g., springs, valve discs, must be suitable for use with LPG and for operation at low temperatures.

7.4.1.7.4 Pressure relief valves installed on the LPG storage vessels shall be designed to protect the vessels during fire exposure. Other causes of tank over pressure, such as overfilling and introduction of material with a higher vapor pressure in a common piping system, shall be considered.

7.4.1.7.5 Pressure relief valves shall be designed and sized in accordance with [IPS-E-PR-450](#) and API Recommended Practice 520, Part 1 and API Recommended Practice 521.

7.4.1.7.6 All safety provisions given by NFPA 58 Chapter 2 under paragraph 2.3.2 and applicable to spring-loaded safety relief valves installation on LPG storage vessels shall be considered to the extent of process design requirements.

7.4.1.7.7 When a closed relief system is used all applicable points of API Publication 2510 A, under Paragraph 2.10.3 shall strictly be considered in process design of the system. Atmospheric relief system if proposed in project specification, requirements of API Publication 2510 A, under Paragraph 2.10.2 shall essentially be taken account in process design of such system.

7.4.1.7.8 Tanks that may be damaged by internal vacuum shall be provided with at least one vacuum relieving device set to open at not less than the partial vacuum design pressure.

7.4.1.7.9 When a closed inner tank design is used with an outer vapor-tight shell, the outer shell shall be equipped with a pressure and vacuum relieving device or devices.

7.4.1.8 LPG tank's other accessories

7.4.1.8.1 Sampling connections

7.4.1.8.1.1 If sampling connections are required, they shall be installed on the tank piping rather than on the tank. Sampling provisions given in API Publication 2510A under Paragraph 3.5 shall to the extent of process design requirements be considered.

7.4.1.8.2 Accessory equipment and shut-off valves

7.4.1.8.2.1 Accessory equipment and shutoff valves shall be designed to meet extreme operating pressure and temperature.

7.4.1.8.3 Liquid level gaging device

7.4.1.8.3.1 Each non-refrigerated storage vessel shall be equipped with a liquid level gaging device of approved design. If the liquid level gaging device is a float type or a pressure differential type and the vessel is a non-refrigerated type, the vessel shall also be provided with an auxiliary gaging device, such as a fixed dip tube, slip tube, rotary gage, or similar device.

7.4.1.8.3.2 Refrigerated LPG storage vessels shall be equipped with a liquid level gaging device of approved design. An auxiliary gaging device is not required for refrigerated storage vessels. However, in lieu of an auxiliary gage, refrigerated vessels, if subject to overfilling, shall be equipped

with an automatic device to interrupt filling of the tank when the maximum filling level is reached.

7.4.1.8.3.3 All other safety requirements relating to liquid level gaging specified in NFPA 58 under Paragraph 3.4.3.3 through 4.4.3.4 and Paragraph 2.3.4 shall be considered.

7.4.1.8.4 Venting non-condensibles

7.4.1.8.4.1 Non-condensable gases, including air, can enter to a LPG storage vessel through a variety of means including the following:

- a) Desolved or entrained gases from processing, such as sweetening.
- b) Operation of vacuum breakers.
- c) System leaks while under vacuum.
- d) Air or inert gas in a vessel when it is put into service.
- e) Vapor return lines from trucks or rail cars that contain air or inert gas prior to loading.

7.4.1.8.4.2 The gases may cause the relief valve to operate when the liquid level is subsequently raised and the noncondensable gases are thereby compressed.

7.4.1.8.4.3 Criteria should be developed to vent the compressed non-condensibles periodically when the oxygen concentration exceeds a specified value or when the head-space pressure exceeds the product vapor pressure by a specified amount.

7.4.1.8.4.4 The non-condensibles may be vented to air. If regulations require venting to a flare system, then caution is necessary, since the vented gas may contain air. In these cases precautions shall be taken to prevent sending a flammable mixture to the flare.

7.4.1.8.5 Drain facilities

7.4.1.8.5.1 A drain connection shall be provided on the filling/discharge line at the manifold side of the first shut-off valve (manual or remote-controlled).

7.4.1.8.5.2 If in exceptional cases a drain connection on the storage vessel is unavoidable, Company's prior approval should be obtained in order to agree on an acceptable design of drainage system.

7.4.1.8.5.3 The outlet of the drain line, where flammable vapor can be released, should be discharged at a safe point, i.e., away from roads, working areas, etc.

7.4.1.8.5.4 At locations where freezing conditions can occur, the drain facilities shall be adequately traced and insulated. Insulation and possibly, tracing of the filling/discharge line may also be necessary.

7.4.1.8.5.5 Operational rules for drainage should be given in operating manual or as an instruction to drainage procedure.

7.4.2 Refrigeration system

7.4.2.1 Load

The refrigeration load should take into consideration the following factors:

- a) Heat flow from the following sources:
 - 1) The difference between the design ambient and storage temperatures.
 - 2) Maximum solar radiation.
 - 3) Receipt of product that is warmer than the design temperature, if such an operation is expected.
 - 4) Foundation heaters.
 - 5) Heat absorbed through connected piping.
- b) Vapor displaced during filling or returned during product transfer.
- c) Changes in barometric pressure.

7.4.2.2 Vapor handling

7.4.2.2.1 The vapor load resulting from refrigeration may be handled by one or a combination of the following methods:

- a) Recovery by a liquefaction system.
- b) Use as fuel.
- c) Use as process feedstock.
- d) Disposal by flaring or another safe method.

Alternative handling methods shall be provided to dispose of vented vapors in case of failure of the normal methods. If compressors are used, castings shall be designed to withstand a suction pressure of at least 121 percent of the tank design pressure.

7.4.2.3 System accessories

7.4.2.3.1 A refrigerated LPG system shall contain the following accessories:

- a) An entrainment separator in the compressor suction line.
- b) An oil separator in the compressor discharges line (unless the compressor is a dry type).
- c) A drain and a gaging device for each separator.
- d) A non-condensable gas purge for the condenser.
- e) Automatic compressor controls and emergency alarms to signal:
 - 1) When tank pressures approach the maximum or minimum allowable tank working pressure or the pressure at which the vacuum vent will open, or
 - 2) When excess pressure builds up at the condenser because of failure of the cooling medium.

7.4.2.4 Pressure relieving devices

7.4.2.4.1 Refer to [IPS-E-PR-450](#) and API Recommended Practice 520, Parts I and II, for the proper design of pressure relieving devices and systems for process equipment used in liquefaction and vaporization facilities.

7.4.3 Pumps

7.4.3.1 Centrifugal or positive displacement pumps may be used for LPG service. The pumps should be able to operate at a low NPSH.

7.4.3.2 In process design of pumps reference is made to [IPS-E-PM-100](#).

7.4.3.3 Centrifugal and rotary positive displacement pumps shall be equipped with mechanical seals. Consideration should be given to the use of auxiliary glands.

7.4.3.4 If centrifugal pump is used, a return line connecting the discharge with the suction side of the pump might be installed. The flow through this return line should be 10-30% of the design flow of the pump at it's highest efficiency.

7.4.3.5 Positive displacement pumps if are used, shall be safeguarded by a differential relief valve in a return line from discharge to suction side. The return line shall be designed for of the designed capacity of the pump.

7.4.3.6 Return line should either run back to the suction line of the pump or to the vapor space of the supplying storage vessel.

7.4.3.7 Centrifugal pumps shall be provided with a vent in order to remove any accumulated vapor before the pump started. This vent shall be connected to the vapor space of the storage vessel or vent to atmosphere at a safe place.

7.4.4 Fire protection facilities

7.4.4.1 Provisions given in API Standard 2510 and the API Publication 2510A as an amendment to API Standard 2510, Section 10 shall be subject to verification or modification through analysis of local conditions and used for process design of an efficient and perfectly reliable protection facilities.

7.4.4.2 For water sprinkler systems see [IPS-E-SF-200](#), "Fire Fighting Sprinkler Systems".

7.4.5 Piping

7.4.5.1 All applicable portions of API Standard 2510 Section 8 shall be followed in process design of piping.

Other considerations for piping process design are those relating parts given in API Publication 2510A under Paragraph 2.7.

7.4.6 Vaporizers

7.4.6.1 General

7.4.6.1.1 Liquefied petroleum gases are used in gaseous form. A vaporizer is required when the heat transferred to the liquid is inadequate to vaporize sufficient gas for maximum demand. A steam, hot water, or direct fired type vaporizer may be used.

7.4.6.1.2 A vaporizer should be equipped with an automatic means of preventing liquid passing from vaporizer to gas discharge piping. Normally this is done by a liquid level controller and positive shutoff of liquid inlet line or by a temperature control unit for shutting off line at low temperature conditions within vaporizer.

7.4.6.1.3 Some installations operate on "Flash Vaporization". Whereby the liquid is converted to a gas as soon as it enters the vaporizer, while others maintain a liquid level in the vaporizer.

7.4.6.2 Indirect vaporizers

7.4.6.2.1 Indirect vaporizers shall comply with Clause 2.5.5.1(a) through (d) of NFPA 58 and the followings:

- a)** A shutoff valve shall be installed on the liquid line to the LPG vaporizer Unit at least 15 meters away from the vaporizer building.
- b)** The heating medium lines into and leaving the vaporizer shall be provided with suitable means for preventing the flow of gas into the heat systems in the event of tube rupture in the vaporizer. Vaporizers shall be provided with suitable automatic means to prevent liquid passing from the vaporizer to the gas discharge piping.
- c)** The device that supplies the necessary heat for producing steam, hot water, or other heating medium shall be separated from all compartments or rooms containing liquefied petroleum gas vaporizers, pumps, and central gas mixing devices by a wall of substantially fire resistant material and vapor-tight construction.

7.4.6.3 Direct fired vaporizers

7.4.6.3.1 Direct fired vaporizers shall be designed in full conformity with requirements given in NFPA 58 under Paragraph 2.5.2 (a) to (f).

7.4.7 Instrumentation

7.4.7.1 As a minimum, the requirements in API Standard 2510, Section 7 shall be followed. In addition, the considerations given in 2.9.1 through 2.9.5 of API Publication 2510A to the extent applicable to process design shall be considered.

7.5 Transfer of LPG Within the Off-Site Facilities of OGP Plants

7.5.1 General

7.5.1.1 LPG as in liquid form is permitted to be transferred from storage vessels by liquid pump or by pressure differential.

7.5.1.2 Pressure differential may be used under certain conditions. Fuel gas or inert gas which is at a higher pressure than of LP gas shall be used under following conditions:

- a) Adequate precautions shall be taken to prevent liquefied petroleum gas from flowing back into the fuel gas or inert gas line or system by installing two back flow check valves in series in these lines at the point where they connect into the liquefied petroleum gas system. In addition, a manually operated positive shutoff valve shall be installed at this point.
- b) Any fuel gas or inert gas used to obtain a pressure differential to move liquid LPG shall be non-corrosive and dried to avoid stoppage by freezing.
- c) Transfer operations shall be conducted by competent trained personnel.
- d) Unloading piping or hoses shall be provided with suitable bleeder valves or other means for relieving pressure before disconnection.
- e) Precaution shall be exercised to assure that only those gases for which the system is designed, examined, and listed are employed in it's operation, particularly with regard to pressure.

7.5.2 Requirements

7.5.2.1 The transfer system shall incorporate a means for rapidly and positively stopping the flow in an emergency. Transfer systems shall be designed to prevent dangerous surge pressures when the flow in either direction is stopped.

7.5.2.2 Transfer pumps may be centrifugal, reciprocating, gear or another type designed for handling LPG. The design pressure and construction material of the pumps shall be capable of safely withstanding the maximum pressure that could be developed by the product, the transfer equipment, or both.

7.5.2.3 All process design requirements under Clause 7.4.3 of this Standard Specification shall be considered when centrifugal or positive displacement pumps are used.

7.5.2.4 Provisions relating to process design requirements of a LPG transfer, loading and unloading facilities given in API Standard 2510, under Paragraph 9, is considered as integral part of this Standard Specification in Section B.

7.5.2.5 All safety considerations deemed necessary to be specified in process design of LPG transfer facilities shall be in conformity with NFPA 58.

SECTION C**8. LIQUEFIED NATURAL GAS (LNG); STORAGE AND TRANSFER FACILITIES****8.1 Introduction**

Liquefied Natural Gas or (LNG) occupies about 1/600 the of it's gaseous volume at Standard Conditions. LNG main constituents, methane (CH₄) and ethane (C₂H₆) in which methane predominates, can not be liquefied by pressure alone, since the critical temperature of these gases is well below ordinary ambient temperature, and some pre-cooling is therefore necessary before they can be liquefied by pressure.

8.2 General Considerations**8.2.1 Physical properties**

8.2.1.1 The properties of natural gas and LNG are similar to those of methane, although the presence of other constituents should be taken into account.

8.2.1.2 Above -113°C, methane vapor is lighter than air. The flammable range for methane is 5% to 15% by volume in air, which is wider than for most other gaseous fuels. The lower flammable limit (5%) and the ignition temperature (632°C) are higher than for other fuels.

8.2.2 Spacing and diking

8.2.2.1 In addition to API Standard 620, Appendix Q, NFPA 59-A, [IPS-E-PR-190](#), and the governing Local Regulations (if any), the following factors shall also be considered for spacing, diking and impounding of LNG storage tank(s) and other process equipment.

- a)** The tank(s) shall be located as far as possible from dwelling areas or locations where large numbers of people are working.
- b)** The tank(s) should have good access from at least two directions, so that fires can be handled if they should occur.
- c)** Necessary impounding and diking design and capacity should be in full conformity with Paragraph 2.2.2 of NFPA 59A. However, other methods of diking including natural topography, steel structural dikes, pre-stressed concrete dikes and a conventional earthen dike using a LNG collection sump within the dike area should be consulted with the Company and used upon his approval.
- d)** The degree to which the facilities can, within limits of practicality, be protected against forces of nature.
- e)** The area around natural gas installation should be kept free from vegetation and other combustible materials. Smoking should be strictly prohibited in the vicinity of the storage facility and suitable warning notices displayed.
- f)** Adequate arrangements for dealing with fire and larger spillages should be made. Instruction and emergency procedure for fire fighting, should be given and regularly practiced. For fire and fire fighting reference shall also be made to BS 5429.

8.3 Criteria and Requirements**8.3.1 Cryogenic process system****8.3.1.1 General**

8.3.1.1.1 Process system equipment containing LNG, flammable refrigerants or flammable gases

shall be either:

- a) Installed outdoors for ease of operation, safe disposal of accidentally released liquids and gases, or;
- b) Installed indoors in enclosing structures complying with NFPA 59A, Paragraphs 2.3.2 and 2.3.3.

8.3.1.2 Pumps and compressors

8.3.1.2.1 Pumps and compressors shall be designed for materials suitable for the temperature and pressure conditions.

8.3.1.2.2 Isolating valves shall be installed so that each pump or compressor can be isolated for maintenance. Pumps or centrifugal compressors discharge lines shall be equipped with check valves.

8.3.1.2.3 Pressure relieving device on the discharge to limit the pressure to maximum safe working pressure of the casing and downstream piping shall be provided.

8.3.1.2.4 The foundations and sumps for cryogenic pumps shall be designed to prevent frost heaving.

8.3.1.2.5 Pumps used for transfer of LNG at temperature below -30°C shall be provided with suitable means for precooling to reduce effect of thermal shock.

8.3.1.2.6 Compression equipment handling flammable gases shall be provided with vents from all points, including distance pieces. Vents shall be piped to a point of safe disposal.

8.3.1.2.7 Not contrary with above, applicable process design requirement in [IPS-E-PR-750](#) shall be considered for compressor design respectively.

8.3.1.3 Storage tanks

8.3.1.3.1 Process design of storage tanks of LNG and refrigerants shall comply with requirements under Section B of this Standard Specification and API Standard 2510 and applicable portions of NFPA 59A, Paragraph 3.3.

8.3.1.3.2 The following should essentially be determined for design:

- a) Purpose of the storage i.e., peak shaving or base load;
- b) Volumetric capacity;
- c) LNG properties;
- d) Operating temperature minimum and maximum;
- e) Operating and design pressure;
- f) Barometric data for sizing relief valve;
- g) External loading;
- h) Evaporation rate.

8.3.1.3.3 Storage tanks may use internal or external pumps. If internal pumps are used, all connections are made in the roof. When external pumps are used, bottom connection shall be made.

8.3.1.3.4 In order to avoid LNG from falling or pouring to the bottom, a tank cooled-down line connected to a sprayrig should be inside at the top of the tank.

8.3.1.3.5 Liquid fill lines may be designed for installation at top, bottom or both.

8.3.1.3.6 In order to provide positive suction head, the tank foundation should be elevated to an appropriate level.

8.3.1.3.7 Insulation

8.3.1.3.7.1 Insulation of low temperature installations in general and refrigerated LNG storage tanks in particular is one of the most critical areas of low temperature storage design.

The selection of any of the following methods:

- a) High vacuum.
- b) Multiple layer.
- c) Powder.
- d) Rigid foam.

Should carefully be studied with specific concern to the capacity of the tank, the temperature, economic and safety requirements.

8.3.1.3.7.2 Any exposed insulation shall be non-combustible, shall contain or inherently shall be a vapor barrier, shall be water free, and shall resist dislodgment by fire hose streams. When an outer shell is used to retain loose insulation, the shell shall be constructed of steel or concrete.

8.3.1.3.7.3 The space between the inner tank and the outer tank shall contain insulation that is compatible with LNG and natural gas and is non-combustible. The insulation shall be such that a fire external to the outer tank will not cause significant deterioration to the insulation thermal conductivity by melting, setting etc.

8.3.1.3.8 Relief devices

8.3.1.3.8.1 The LNG storage tank shall be protected when overpressured by safety relief valve(s) providing an effective rate of discharge. The minimum required rate of discharge shall be determined so as to prevent pressures exceeding those allowed by the governing code giving proper consideration to fire exposure, process upsets or loss of product.

8.3.1.3.8.2 Sizing, locating, installing of necessary relieving devices shall be in accordance with provision of API Standard 620, Appendix N therein. Safety requirement under Paragraph 4.7 of NFPA Standard 59A, shall also be considered for applicable portions in process design.

8.3.1.3.9 Instrumentation

8.3.1.3.9.1 Each LNG storage tank shall be equipped with an adequate liquid level gaging device. Density variations shall be considered in the selection of the gaging device. Considerations shall be given to a secondary or backup gaging. At least one of these gages shall be replaceable without taking the tank out of operation.

8.3.1.3.9.2 The storage tank shall be provided with a high-liquid level alarm which shall be separate from the liquid level gaging device.

8.3.1.3.9.3 Each tank shall be equipped with a pressure gage connected to the tank at a point above the maximum intended liquid level.

8.3.1.3.9.4 Vacuum-jacketed tank shall be equipped with instruments or connections for checking the absolute pressure in the annular space.

8.3.1.3.9.5 Temperature monitoring devices shall be provided in field erected storage tanks to assist in controlling temperatures when placing the tanks into service or as a method of checking and calibrating liquid level gages.

8.3.1.3.9.6 In addition to requirements of 8.3.1.3.9 above, all instrumentation requirement given in Section B for storage tanks of LPG shall also be considered as minimum requirement for LNG tanks.

8.3.1.3.10 Other requirements

8.3.1.3.10.1 To control corrosion rate in the specified level for the tank if the bottom of the tank rests directly on the ground, appropriate cathodic protection should be established, if required in the project specification.

8.3.1.3.10.2 All tanks in which water might accumulate under the hydrocarbon contents shall be provided with adequate drains that are suitably protected from freezing.

8.3.1.3.10.3 All openings and accessories for tanks constructed according to this Standard shall be installed so that any period checking, inspection, cleaning etc., can readily be made.

8.3.1.4 Piping system design requirements

8.3.1.4.1 All piping systems shall be designed in accordance with ANSI/ASME B31.4. The additional provisions as given hereunder shall be applicable to pressurized piping systems and components for LNG, flammable refrigerants, flammable liquids and gases or low pressure piping systems including vent lines and drain lines which handle LNG, flammable refrigerants, with service temperatures below -30°C .

8.3.1.4.2 Piping systems and components shall be designed to accommodate the effects of fatigue resulting from the thermal cycling to which the systems will be subjected. Particular consideration shall be given where changes in size or wall thickness occur between pipes, fittings, valves and components.

8.3.1.4.3 Provision for expansion and contraction of piping and piping joints due to temperature changes shall be in accordance with Clause 319 of ASME B31.3.

8.3.1.4.4 All piping materials including gaskets and thread compounds, shall be suitably used with the liquids and gases handled throughout the range of temperatures to which they will be subjected. The temperature limitations for pipe materials shall be as specified in ASME B31.3.

8.3.1.4.5 Safety requirements for piping process design as given in Chapter 6 of NFPA, 59A shall be considered.

8.4 Transfer of LNG and Refrigerants

8.4.1 General requirements

8.4.1.1 Transfer facilities shall comply in process design requirements and criteria with appropriate provisions elsewhere in this Standard, such as those applying to siting, piping and instrumentation, safety considerations as well as the following specific provisions:

8.4.1.1.1 When making bulk transfers into stationary storage tanks, the LNG being transferred shall be:

- a) compatible in composition or temperature and density with that already in the container, or;
- b) when the composition or temperature and density are not compatible, instruction shall be given in operating manual to prevent stratification which might result in "roll over" and an excessive rate of vapor evolution;
- c) stratification can be prevented by means such as: introducing the denser liquid above the surface of the stored liquid, introducing mechanical agitation, or introducing the LNG into the tank through an inlet nozzle designed to promote mixing. If agitation system or mixing nozzle is provided it shall be designed for sufficient energy to accomplish its purpose.

8.4.2 Piping system

8.4.2.1 Isolating valves shall be installed so that each transfer system can be isolated at its extremities.

8.4.2.2 When power operated isolating valves are used, a design analysis should be made to determine that the closure time will not produce a hydraulic shock capable of causing line or equipment failure.

8.4.2.3 Check valves shall be provided as required in transfer systems to prevent backflow and shall be located as close as practical to the point of connection to any system from which backflow might occur.

8.4.2.4 A piping system used for periodic transfer of cold LNG, shall be provided with suitable means for pre-cooling before use.

8.4.2.5 All applicable provisions to process design of LNG transfer system given under Chapter 8, of NFPA, 59A shall be considered as an integral part of requirements of this Section.

8.5 Fire Protection

8.5.1 Fire protection system shall be considered for all LNG facilities. In process design of the system, the extent of protection shall be evaluated with specific concern to a sound fire protection engineering principles, to provisions of [IPS-E-SF-200](#), local conditions, process hazards, and NFPA 59A requirements under Chapter 9.

SECTION D**9. STORAGE AND HANDLING OF ETHANE AND ETHYLENE****9.1 General****9.1.1 Scope**

9.1.1.1 This Section covers the requirements and criteria for process design of ethane and ethylene storage facilities installed at refineries, natural gas processing plants, petrochemical plants, pipeline terminals and tank farms (except above-ground concrete tanks, frozen earth pits and under-ground storage caverns or wells).

9.1.2 Reference publications

9.1.2.1 The latest edition or revision of API Standard 2508, "Design and Construction of Ethane and Ethylene Installation" along with latest edition and revision of publications specified thereon shall to the extend specified, form a part of this Section requirements.

9.2 Applicable Design Codes on Temperature and Pressure

9.2.1 Applicable requirements of the following shall be considered in process design:

- a) ASME Boiler and Pressure Vessel Code, Section VIII.
- b) API Standard 620 and [IPS-E-PR-360](#), Sections B & C.
- c) Safety requirements at least equal to those specified in API Standard 2510 and NFPA 59A and [IPS-E-PR-360](#) Sections B and C.

9.2.2 The refrigeration system shall maintain the ethane and ethylene at a temperature such that it's vapor pressure does not exceed the design pressure of the tank. For systems at or near atmospheric pressure, consideration should be given to design for additional refrigeration necessary as a result of changes in atmospheric pressure.

9.2.3 The tank above the maximum liquid level shall be designed for a pressure not less than that at which the pressure relief valves are to be set and for the maximum partial vacuum that can be developed.

9.2.4 All portions of the tank below the maximum liquid level shall be designed for at least the most severe combination of gas pressure (or partial vacuum) and static liquid head affecting each element of the tank.

9.2.5 The design temperature shall be the minimum temperature to which the tank contents will be refrigerated. The minimum temperatures of the part of the country where the tank is to be built shall be considered in the design. Provisions shall be made to minimize thermal stress concentration during initial cool down of a tank.

9.3 Distance Requirements and Exposure Limitations**9.3.1 General**

9.3.1.1 Site selection shall include consideration of existing facilities, planned facilities in immediate area, and the location of facilities adjoining the installation.

9.3.2 Minimum distance requirement and layout

9.3.2.1 All applicable provisions of [IPS-E-PR-190](#) shall be considered for layout and spacing of above ground ethane and ethylene storage tanks together with following requirements. In case of any contradiction between these requirements and provisions of above said IPS, the most protective for safety requirements shall be employed:

- a) The minimum distance from the lines of adjoining property that may be built upon to the tank shell shall be a distance of one-and-one half the tank diameter or 60 meters whichever

is less.

b) The minimum distance between the outer surfaces of the shells of adjacent ethane and ethylene tanks shall be a distance of one-fourth the sum of the diameters of the adjacent tanks.

c) The minimum distance from the tank shell horizontally to overhead power transmission lines, surface equipment of storage caverns, regularly occupied buildings, loading and unloading facilities, or stationary internal combustion engines shall be 7.5 meters. These facilities shall not be built within a diked area.

d) The minimum distance from the tank shall to navigable waterways, docks and piers shall be 15 meters.

9.3.3 Exposure and other limitations

9.3.3.1 The following conditions are required for locating facilities:

a) Ethane and ethylene storage tanks shall be located outside of buildings.

b) Tanks containing flammable or combustible liquids (other than ethane/ethylene) shall not be located inside the dike surrounding ethane and ethylene storage tanks.

9.3.4 Dike and drainage provisions

9.3.4.1 Drainage systems shall have a grade of one percent or greater and shall terminate in a surface area. Drainage systems shall have a capacity not less than that of the largest tank served.

9.3.4.2 All other provisions of API Standard 2508 regarding to dike and drainage of ethane and ethylene storage tanks and subject to process design consideration shall be used.

9.4 Tank Accessories

9.4.1 General

9.4.1.1 Tanks shall be fitted with the following devices/equipment as suitable for use with ethane/ethylene and designed for not less than service conditions to which it may be subjected:

9.4.2 Liquid level indicator

9.4.2.1 Each tank shall be equipped with a suitable liquid level indicator. The use of a secondary or backup indicator shall be considered. At least one of these indicators shall be replaceable without taking the tank out of operation. Columnar glass gages shall not be used.

9.4.3 Level alarm

9.4.3.1 Each tank shall be provided with a high liquid-level alarm, which is to be a separate device from the gaging device specified in 9.4.2.1 above. The alarm shall be set so that the operator will have sufficient time to stop flow without exceeding the maximum permissible filling height. The alarm shall be located so that it is audible to personnel controlling the filling. A high level flow-cutoff device, if used, shall not be considered as a substitute for the alarm.

9.4.4 Pressure gage

9.4.4.1 A pressure gage connected to the vapor space shall be provided on each tank.

9.4.5 Pressure and vacuum relieving devices

9.4.5.1 Each tank shall be provided with one or more spring-loaded, weighted-pallet, or pilot-operated pressure-relief devices. For tanks designed for 104 kPa (ga) or more, the pressure relief valves shall be set to start to discharge in accordance with the applicable paragraphs of the ASME Code Section VIII. Weighted-pallet valves shall not be used where start-to-discharge pressure exceeds 104 kPa (ga). Weight and lever pressure-relieving devices shall not be used.

9.4.5.2 For tanks designed for pressures below 104 kPa (ga), the pressure relief device shall be set to discharge at no more than the maximum allowable working pressure of the tank.

9.4.5.3 Pilot-operated pressure-relief devices shall be so designed that the main valve will open

automatically and protect the tank in the event of failure of the pilot valve or other essential functioning device.

9.4.5.4 Each tank that may be damaged by partial vacuum shall be provided with at least one vacuum-relieving device. The vacuum setting shall be such that the partial vacuum developed in the tank at the maximum specified rate of air (or gas) inflow will not exceed the partial vacuum for which the tank is designed.

9.4.5.5 When double-wall construction is used in which the inner tank holding ethane and ethylene is surrounded by insulation contained within an outer vapor-tight jacket, the jacket shall be equipped with a pressure and vacuum relieving device or devices. These devices shall be set to open at no more than the maximum allowable working pressure and vacuum of the outer tank.

9.4.5.6 In addition to requirements specified under 9.4.5.1 through 9.4.5.5 above, all of the provision under 5.1.5 through 5.1.11 of API Standard 2508 shall be considered as an integral parts of this section for ethane/ethylene storage tanks accessories.

9.4.5.7 Sampling connections

9.4.5.7.1 Sampling connections, if required, shall be installed on tank piping rather than on the tank.

9.4.5.8 Automatic and remote devices

9.4.5.8.1 Automatic shutoff valves, remotely operated shutoff valves, automatic warning devices, or a combination of these shall be used where tanks are remotely operating, receive ethane and ethylene at a high rate of flow, or in other circumstances in which the designer considers it advisable.

9.5 Piping Requirements

9.5.1 Piping shall conform to the applicable provisions of API Standard 2508, Section 6, and the following:

9.5.1.1 Insofar as possible, all header piping, loading and unloading connections to and from the tank, and so forth should be simplified. For example, a minimum number of connections into and out of the storage tank is desirable. Operating errors increase as the piping installation becomes more complex.

9.5.1.2 Shutoff valves that must be used during normal operations should be accessible to an operator for ease of maintenance and for safety of operation and should be as close to the tank, pump, compressor, or other equipment as possible. This should not be construed as prohibiting the installation of remote shutoff valves or other safety appurtenances.

9.5.1.3 Buried pipelines should be installed below the frost line and protected from corrosion.

9.5.1.4 Connections from tanks to loading and unloading headers, equalizing lines, and vent or relief lines should be installed to permit flexibility in all planes. Necessary ells or bends should be provided for possible vertical and horizontal movement between the tank and the header.

9.5.1.5 In long lines where expansion and contraction are known to exist, each line should be equipped with an adequate expansion bend or angular offset.

9.5.1.6 It is recommended that emergency shutoff valves be installed in long runs of piping used to carry liquids to prevent the contents from being released in the event of line or equipment failure.

9.6 Transfer, Loading and Unloading Facilities

9.6.1 Sizing

9.6.1.1 Pumps and loading devices shall be sized to provide rates of flow appropriate to the capacity of the facility. Extreme care shall be taken to ensure that the rates of flow are such that the operator can follow the course of loading and unloading at all times and have adequate time to shut down the facility before the tank or tanks are emptied completely or before they are filled beyond their maximum filling height.

9.6.2 Design

9.6.2.1 The transfer system shall incorporate a means for rapidly and positively stopping the flow in an emergency. Transfer systems shall be designed such that dangerous surge pressures cannot be

generated when the flow in either direction is stopped.

9.6.3 Equipment

9.6.3.1 Pumps

9.6.3.1.1 Pumps may be centrifugal, reciprocal, gear, or other types designed for handling refrigerated liquid ethane and ethylene. They shall have a design pressure and shall be constructed of material capable of safely withstanding the temperature and maximum pressure which could be developed by the product, the transfer equipment, or both.

9.6.3.1.2 Positive displacement pumps shall have a suitable relief device on the discharge side unless other provisions are made for protection of equipment.

9.6.3.1.3 Centrifugal pumps equipped with mechanical seals or ordinary stuffing boxes are acceptable; however mechanical seals are preferred.

9.6.3.2 Process design requirements of other equipment such as valves including emergency shutoff valves, compressors, flow indicators, etc., shall be taken in full conformity with API Standard 2508.

9.7 Refrigeration System

9.7.1 Refrigeration load

9.7.1.1 The refrigeration load should take into consideration the following factors:

- a) Temperature difference between design ambient temperature and design storage temperature.
- b) Maximum solar radiation.
- c) Receipt of product that is warmer than the design temperature, if such operation is expected.
- d) Foundation heaters.
- e) Heat absorbed in connected pipe.
- f) Vapor displaced during filling or returned during product transfer.
- g) Barometric pressure changes.

9.7.2 Other requirements

9.7.2.1 For other requirements of system process design, provisions given in API Standard 2508 shall be considered.

SECTION E

10. STORING AND HANDLING OF ETHANOL AND GASOLINE - ETHANOL BLENDS

10.1 General

10.1.1 Motor fuels resulting from blend of 10 percent denatured anhydrous ethanol and 90 percent gasoline have properties similar to those of gasoline. There are differences, however, which must be recognized by those who store, handle, or provide fire protection for blended products. The facilities required for the handling of ethanol blend are also similar to those for gasoline, with some minor exceptions.

10.2 Scope

10.2.1 This section describes process design requirements for storing, handling and fire protection of ethanol and gasoline-ethanol blends at distribution terminals.

10.3 Material Selection

10.3.1 Most materials used in storing, blending and transfer of gasoline are also suitable for use with ethanol and ethanol blend. However engineering judgment is required when selecting materials for use with ethanol and ethanol blend to ensure the safeties that handle these liquids. Some commonly used materials and their compatibility with ethanol and ethanol blend are listed in Table 4.

TABLE 4 - COMPATIBILITY OF COMMONLY USED MATERIALS WITH ETHANOL AND ETHANOL BLEND

RECOMMENDED	NOT RECOMMENDED
METALS	
Aluminum Carbon steel Stainless steel Bronze	Zinc-galvanized (ethanol only)
ELASTOMERS	
Buna-N (hoses and gaskets) (Note 1) Fluorel (Note 1) Fluorosilicone (Note 2) Neoprene (hoses and gaskets) Polysulfide rubber Natural rubber (ethanol only) Viton (Note 1)	Buna-N (seals only) (Note 1) Neoprene (seals only) Urethane rubber
POLYMERS	
Acetal Nylon Polyethylene Polypropylene Teflon (Note 1) Fiberglass reinforced Plastic (Note 2)	Polyurethane (Note 2) Alcohol-based pipe dope (recently applied) (Note 2)

Notes:

- 1) Registered trademark.**
- 2) The manufacturer of the specific material should be considered.**

10.4 Requirements

10.4.1 Tanks and tank lining

10.4.1.1 Ethanol or ethanol blend should be stored in a tank with a fixed roof and an internal floating cover. As an alternative, ethanol may be stored in a small cone roof tank without a floating cover provided that air quality requirements are met.

10.4.1.2 To minimize vapor losses and where tank design permits, a 450 Pa pressure, 30 Pa vacuum pressure-vacuum vent made for ethanol service should be installed.

10.4.1.3 In some locations, it may be necessary to dry the air going into the tank to avoid condensation of moisture that might contaminate the ethanol. Fig. D.1 in Appendix D provides an example of such an installation. It is important that the tank pressure-vacuum valve admit air into the tank only when the air-dryer system fails or malfunctions. This can be done by ensuring that the vacuum pallet on the tank pressure-vacuum valve is set at a vacuum higher than that of the air-dryer vacuum relief valve.

10.4.1.4 To prevent any spill from spreading, it is desirable to separate tanks used to store ethanol and their air-dryer systems from other tanks that contain flammable liquids by using intermediate curbs, dikes, or drainage channels. In all other respects, tanks used to store ethanol and their air-dryer systems should comply with generally accepted standards for the storage of flammable liquids, such as those given in NFPA 30, Flammable and Combustible Liquids Code.

10.4.1.5 Riveted tanks should not be used because they are more likely to leak.

10.4.2 Handling

10.4.2.1 Ethanol should be blended with gasoline using the in-line blender or the in-tank blender. Track blending is not recommended. (See Paragraph 2.2 of API Recommended Practice 1626, for detail.)

10.4.2.2 For safe handling of gasoline and the ethanol-gasoline blend the accepted industry practice as described in API Recommended Practice 2003 should be followed.

10.4.3 Piping

10.4.3.1 Approved non-metallic pipe or cathodically protected Schedule 40 steel pipe can be used subject to the cautions stated in API Recommended Practice 1626, 1st. Ed., 1985, Paragraph 1.6.1.1 through 1.6.1.3.

10.5 Safety and Fire Protection

10.5.1 All of the applicable safety and fire protection provision, given in API Recommended Practice 1626, Section 4, and applicable NFPA standards shall be considered in process design for storage, piping, handling and operation of these facilities.

SECTION F**11. STORING AND HANDLING OF GASOLINE - METHANOL/COSOLVENT BLENDS****11.1 General**

11.1.1 Motor fuels that consist of a blend of gasoline, methanol, a cosolvent or solvents, and corrosion inhibitors have properties similar to those of gasoline that is not blended with these additives. With some exceptions, the facilities required for the handling of gasoline methanol/cosolvent blends are also similar to those required for gasoline. There are, however, differences that must be considered in storing, handling or providing fire protection of this blend product.

11.1.2 Methanol is an alcohol with a wide variety of use as a solvent. It also serves as a basic building block for production of other chemicals and as a high-octane blending component for gasoline.

11.1.3 Cosolvent alcohols act as a link between methanol and other gasoline components. They improve a gasoline methanol blend's water-tolerance properties. Cosolvents also help control the effect of methanol on the vapor pressure of the finished gasoline methanol/cosolvent blend.

11.2 Material Selection

11.2.1 Most materials used in storing, blending, and transferring of gasoline are also suitable for use with gasoline methanol/cosolvent blends; however, sound engineering judgment is required when materials selection is for use in gasoline methanol/cosolvent blends to ensure the safety of facilities that handle these liquids.

11.2.2 Some commonly used materials and their compatibility with gasoline-methanol/cosolvent blends are listed in Table 5 which should be checked along with other materials for their best suitability for use and selection.

11.2.3 Once the facilities are designed, installed and put into operation, it should be inspected for suitability of selected materials periodically and should promptly be corrected/replaced in case of any malfunction or improper selection.

11.3 Requirements

11.3.1 Following the requirements in Paragraph 11.2, above all of the provisions and specific requirements set forth in API Recommended Practice 1627, (latest edition of this Practice) as applicable to process design of storage and handling facilities of gasoline-methanol/cosolvent, blends shall be considered, as integral part of this section.

11.3.2 The storage tanks used, should comply with generally accepted standards for storage of flammable liquids, such as those given in NFPA 30 and NFPA 30A.

**TABLE 5 - COMPATIBILITY OF COMMONLY USED MATERIALS
WITH GASOLINE-METHANOL/COSOLVENT BLENDS**

RECOMMENDED ^{a)}	NOT RECOMMENDED
METALS	
Aluminum Carbon steel Stainless steel Bronze	Galvanized metals
ELASTOMERS	
Buna-N ^{b, c)} Fluorel ^{b)} Fluorosilicone ^{d)} Neoprene ^{c)} Polysulfide rubber Viton ^{b)}	Buna-N ^{b, c)} Neoprene ^{c)}
POLYMERS	
Acetal Nylon Polyethylene Polypropylene Teflon ^{b)} Fiberglass reinforced plastic ^{d)}	Polyurethane ^{d)} Alcohol-based pipe dope (recently applied) ^{d)}

Notes:

- a) These recommendations may not apply to phase-separated blends or to the gasoline-methanol/cosolvent blending components. The manufacturer of the specific material should be consulted.**
- b) Registered trademark.**
- c) Buna-N and neoprene are recommended for hoses and gaskets but not seals.**
- d) The manufacturer of the specific material should be consulted.**

APPENDICES

APPENDIX A

TABLE A.1 - NOMINAL CAPACITIES OF STANDARD VERTICAL CYLINDRICAL TANKS
TO BS 2654

Height	Tank diameter(m)																	Tank dia
	3	4	6	8	10	12.5	15	17.5	20	22.5	25	27.5	30	33	36	39	42	45
	Nominal capacities																	
m	m ³	m ³	m ³	m ³	m ³	m ³	m ³	m ³	m ³	m ³	m ³	m ³	m ³	m ³	m ³	m ³	m ³	m ³
1	7	12	28	50	78	122	176	240	314	397	490	593	706	855	1017	1194	1385	1590
2	14	25	56	100	157	245	353	481	628	795	981	1187	1413	1710	2035	2389	2770	3180
3	21	37	84	150	235	358	530	721	942	1192	1472	1781	2120	2565	3053	3583	4156	4771
4	28	50	113	201	314	490	706	962	1256	1590	1963	2375	2827	3421	4071	4778	5541	6361
5	35	62	141	251	392	613	883	1202	1570	1988	2454	2969	3534	4276	5089	5972	6927	7952
6	42	75	160	301	471	736	1060	1443	1884	2385	2945	3563	4241	5131	6107	7167	8312	9542
7		87	197	351	549	859	1237	1683	2199	2783	3436	4157	4048	5987	7125	8362	9669	11133
8		100	226	402	628	981	1413	1924	2513	3180	3926	4751	5654	6842	8142	9556	11083	12723
9			254	452	706	1104	1500	2164	2827	3578	4417	5345	6301	7697	9160	10751	12468	14313
10			282	502	785	1227	1767	2405	3141	3976	4908	5939	7068	8552	10178	11945	13854	15904
11				552	863	1349	1943	2645	3455	4373	5399	6533	7775	9408	11169	13140	15239	17494
12				603	942	14/2	2120	2886	3769	4771	5890	7127	8482	10293	12214	14335	16625	19085
13					1021	1505	2297	3126	4084	5168	6381	7721	9189	11118	13232	15599	18010	20675
14					1099	1718	2474	3367	4398	5566	6872	8315	9096	11074	14250	16724	19396	22266
15					1178	1840	2650	3607	4712	5964	7363	8009	10602	12829	15268	17918	20781	23856
16					1256	1963	2827	3848	5026	6361	7856	9503	11209	13684	16285	19113	22167	25446
17						2080	3004	4088	5340	6759	8311	10097	12016	14540	17303	20308	23562	27037
18						2208	3180	4329	5654	7156	8835	10691	12723	15395	18321	21502	24937	28627
19						2331	3357	4570	5969	7554	9326	11285	13430	16250	19339	22697	26323	30218
20						2454	3534	4810	6283	7052	9817	11879	14137	17105	20357	23801	27708	31808
21							3711	5051	6597	8349	10008	12473	14844	17961	21375	25086	29094	33399
22							3887	5291	6911	8747	10799	13067	15550	18816	22393	26280	30479	34989
23							4004	5532	7225	9144	11290	13661	16257	19671	23411	27475	31865	36579
24							4241	5772	7539	9542	11780	14254	16964	70527	24428	28670	33250	38170
25							4417	6013	7853	9940	12271	14848	17671	21382	25449	29864	34636	39700

APPENDIX B

TYPICAL LAYOUT LPG PRESSURE STORAGE WITH COLLECTION PIT/RETAINING SYSTEM

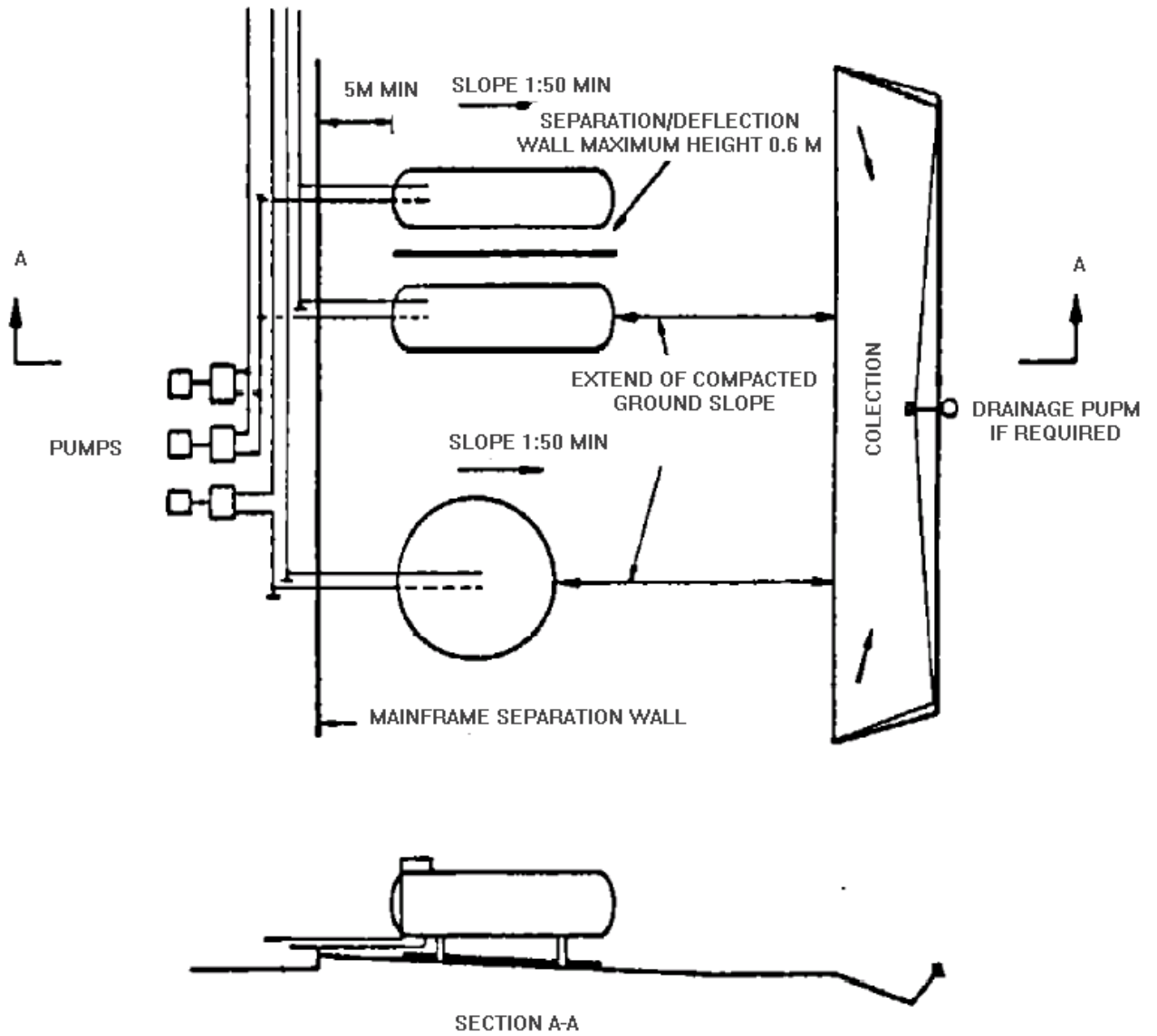

APPENDIX C
ARRANGEMENT OF DRAIN FACILITIES

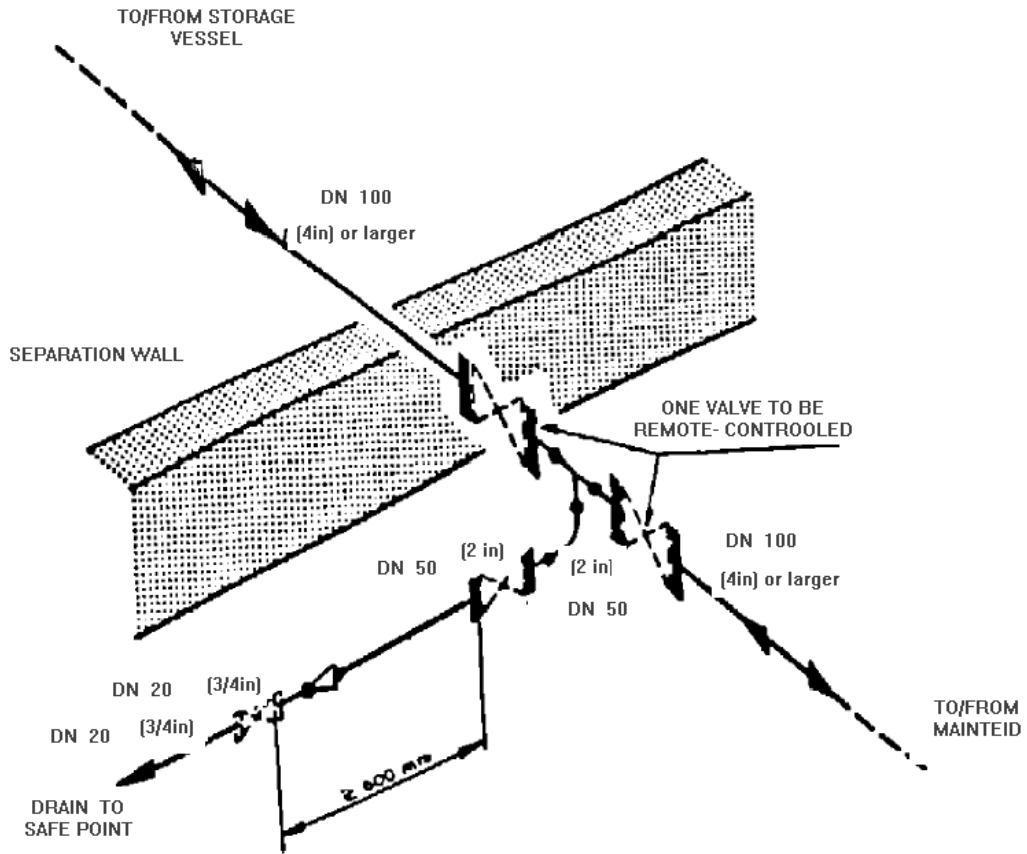

Note:

Drain line to be adequately supported against reaction forces.

APPENDIX D
AIR - DRYER INSTALLATION FOR ETHANOL STORAGE TANKS AT TERMINALS

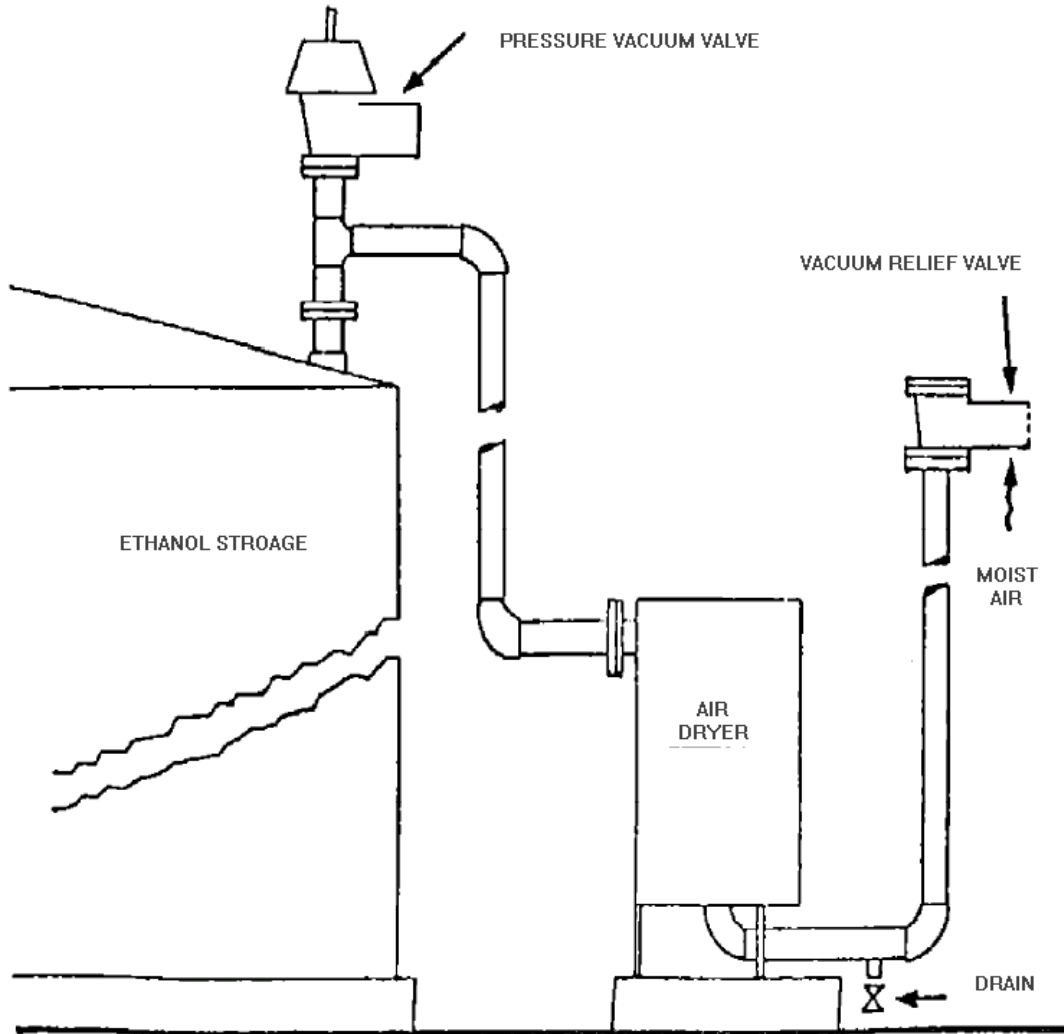

Fig D.1

APPENDIX E
REFINERIES LIQUEFIED PETROLEUM GAS SPECICATION

ANALYSIS	UNIT	LIMIT	TEST METHOD
C2 Hydrocarbon	Vol%	0.2 max	ASTM D 2163
C3 Hydrocarbon	Vol%	*	ASTM D 2163
C4 Hydrocarbon	Vol%	*	ASTM D 2163
C5 Hydrocarbon	Vol%	2 max	ASTM D 2163
Hydrogen sulphide	-	Negative	ASTM D 2420
Mercaptan sulphur gram/m ³		0.23 max(1)	IP. 104 (A)
Odorizing Agent gram/m ³		12	

Note: (1) The limit applies to the product before addition of odorizing agent (Ethyl mercaptan)

* varies seasonally for refineries as follows:

(ABADAN, BANDAR ABBAS)

	1 st KHORDAD TO 1 st MEHR	1 st MEHR TO 1 st AZAR	1 st AZAR TO 1 st ESFAND	1 st ESFAND TO 1 st KHORDAD
C ₃ 's vol%	15-35	30-50	50-70	30-50
C ₄ 's vol%	85-65	70-50	50-30	70-50

(TEHRAN, ARAK, SHIRAZ, KERMANSHAH, ESFAHAN)

	1 st KHORDAD TO 1 st SHAHRIVAR	1 st SHAHRIVAR TO 1 st ABAN	1 st ABAN TO 1 st FARVARDIN	1 st FARVARDIN TO 1 st KHORDAD
C ₃ 's vol%	15-35	30-50	50-70	30-50
C ₄ 's vol%	85-65	70-50	50-30	70-50

(TABRIZ)

	1 st TIR TO 1 st SHAHRIVAR	1 st SHAHRIVAR TO 1 st ABAN	1 st ABAN TO 1 st ORDIBEHESHT	1 st FARVARDIN TO 1 st KHORDAD
C ₃ 's vol%	15-35	30-50	50-70	30-50
C ₄ 's vol%	85-65	70-50	50-30	70-50